

# W3 *Tipi* Type

# WINMAN ÇİFT ETKİLİ SİLİNDİR MILL TYPE DESIGN

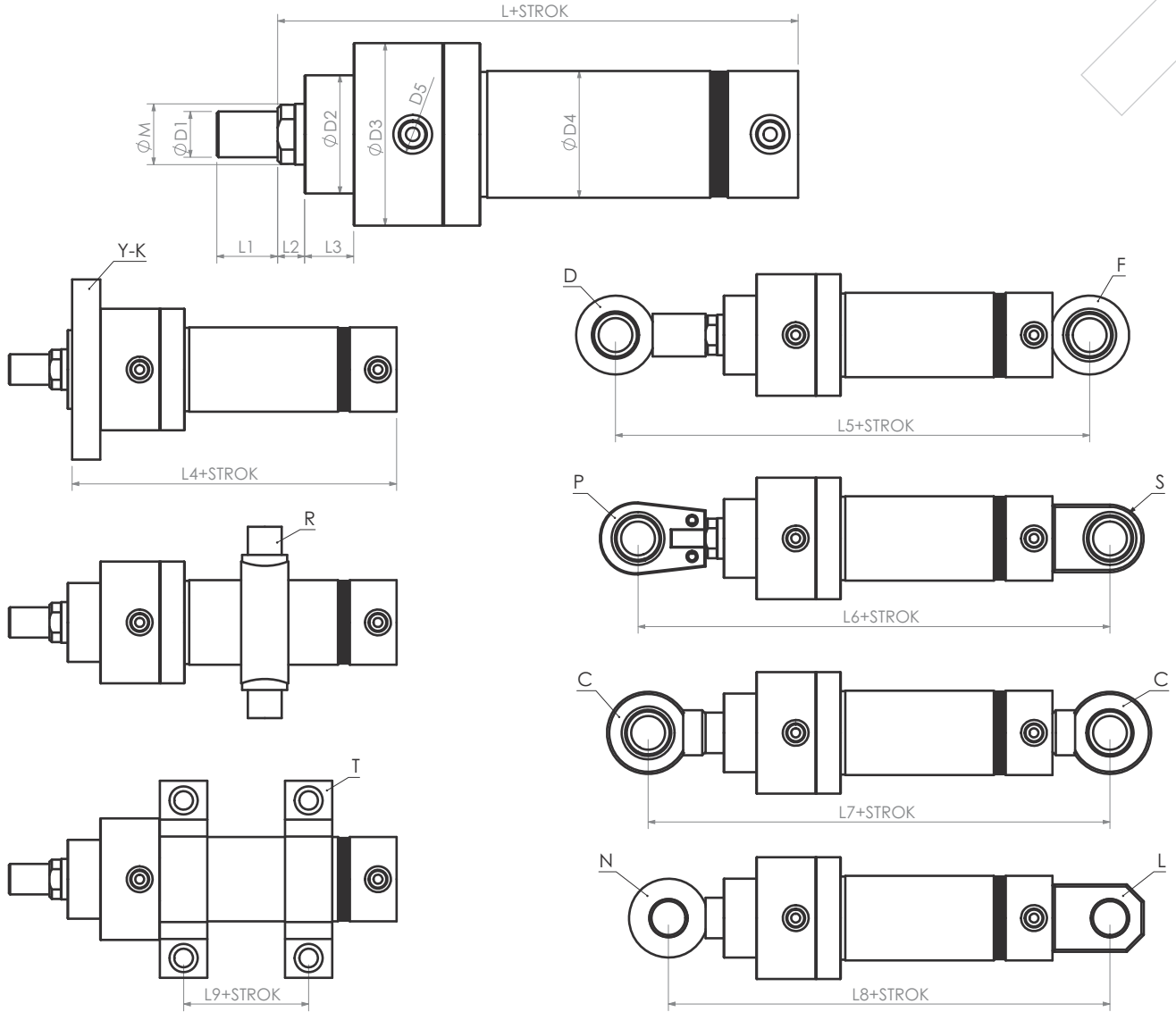

PİSTON	M	AA	D1	D2	D3	D4	D5	D6	D7	D8	D9	D10	D11	D12	D13	L	L1	L2	L3	L4
32	16	14	M12x1,5	40	68	40	1/4"	110	92	9	20	16	-	-	10.5	155	16	13	19	139
	18	16	M14x1,5														18			
40	22	18	M16x1,5	50	78	50	3/8"	125	106	9	25	20	M16x1,5	M16*1,5	10.5	174	22	13	19	158
	28	24	M20x1,5														28			
50	28	24	M20x1,5	60	98	60	3/8"	148	126	11	30	25	M20x1,5	M16*1,5	12.5	185	28	14	24	167
	36	30	M27x2														36			
63	36	30	M27x2	70	108	75	3/8"	170	145	13	40	30	M27x2	M22*1,5	16.5	208	36	16	29	188
	45	38	M33x2														45			
80	45	38	M33x2	85	129	95	1/2"	195	165	17.5	50	40	M33x2	M35*1,5	20.5	236	45	18	36	214
	56	48	M42x2														56			
100	56	48	M42x2	106	158	115	1/2"	238	200	22	60	50	M42x2	M45*1,5	24.5	275	56	20	37	250
	70	60	M48x2														63			
125	70	60	M48x2	132	186	145	3/4"	272	235	22	70	60	M48x1,5	M58*1,5	24.5	297	63	23	37	269
	80	70	M56x2														75			
140	80	70	M56x2	145	210	160	3/4"	296	260	22	80	70	M56x2	M65*1,5	-	328	75	25	40	298
	90	80	M64x3														85			
160	90	80	M64x3	160	240	180	1"	316	280	22	95	80	M64x3	M80*1,5	-	339	85	25	41	309
	100	90	M72x3														90			
180	100	90	M72x3	185	262	210	1"	365	320	26	105	90	M72x3	M100*1,5	-	377	90	30	45	342
	110	95	M80x3														95			
200	110	95	M80x3	200	299	245	1"	385	340	26	115	100	M80x3	M110*1,5	-	397	95	30	45	362
	120	100	M85x3														100			

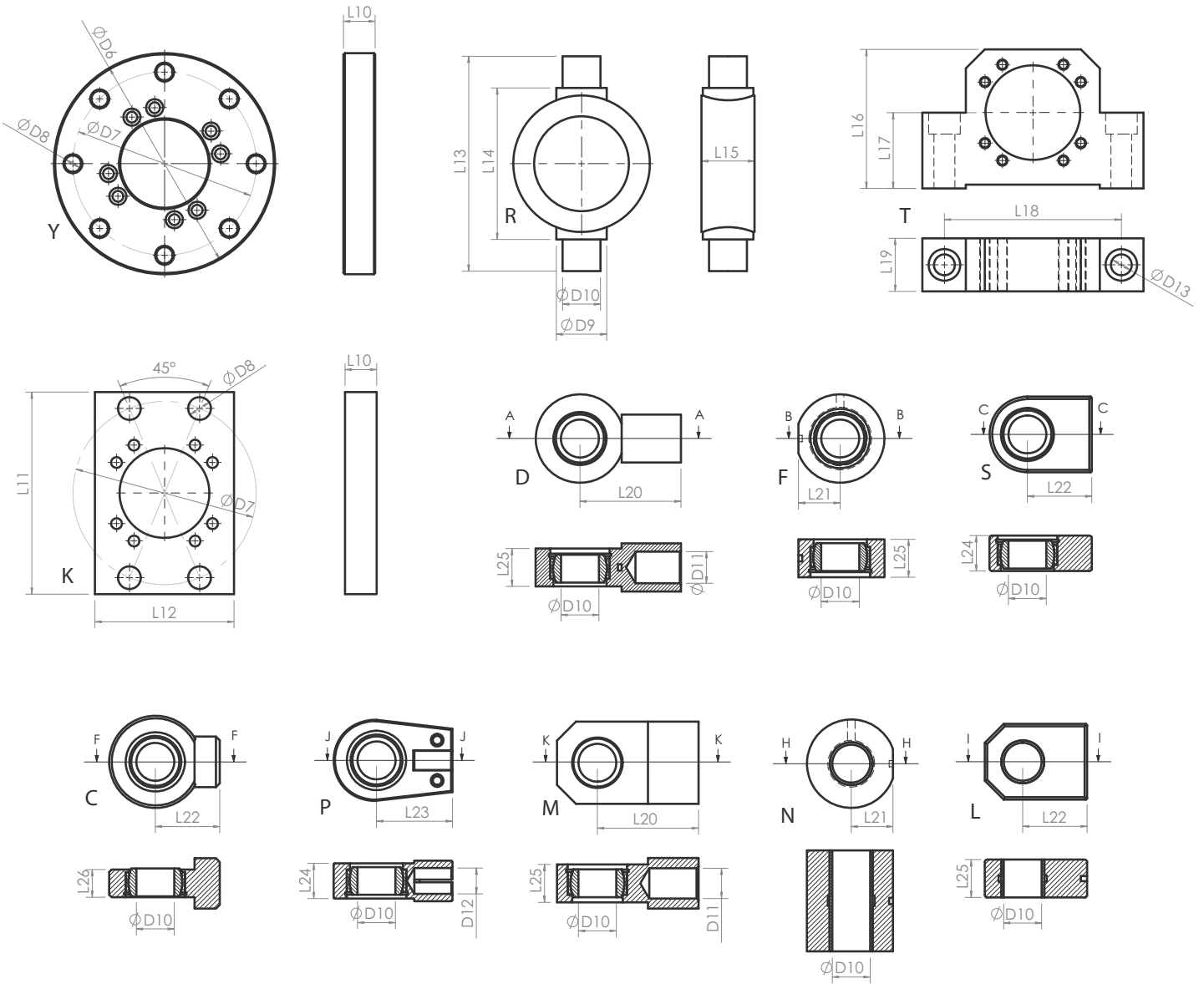

L5	L6	L7	L8	L9	L10	L11	L12	L13	L14	L15	L16	L17	L18	L19	L20	L21	L22	L23	L24	L25	L26
-	-	-	-	-	16	105	70	99	75	30	65	35	85	30	-	-	-	-	-	-	-
254	267	255	240	36	16	115	80	122	90	30	75	40	100	30	52	23	38	50	19	20	16
283	285	280	263	30	20	140	90	145	105	36	90	50	125	36	65	28	45	50	23	25	20
326	324	315	297	24	25	160	110	170	120	42	110	60	140	42	80	33	51	60	28	30	22
381	395	379	353	24	32	182	125	199	135	52	130	69	175	52	97	43	69	85	35	35	28
453	473	456	421	22	32	220	150	220	160	62	155	80	220	62	120	53	88	105	40	40	35
505	532	502	465	8	32	252	180	295	195	76	200	105	245	76	140	63	100	130	50	50	44
563	598	563	518		35	-	-	332	220	86	-	-	-	-	160	70	115	150	55	55	49
604	655	626	565		36	-	-	366	240	96	-	-	-	-	180	80	141	170	60	65	55
667	742		622		40	-	-	415	275	110	-	-	-	-	195	90	150	210	65	75	-
712	807		672		40	-	-	475	315	120	-	-	-	-	210	100	170	235	70	85	-