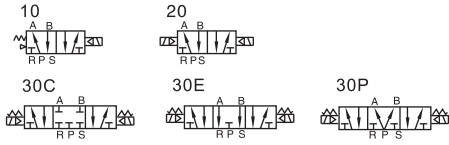

**WINMAN Solenoid Valf (5/2 yollu, 5/3 yollu) / Solenoid Valve (5/2 way, 5/3 way)**

4V400 Serisi / 4V400 Series

**Özellikler / Specification**

Model	4V410-15	4V420-15	4V430C-15	4V430E-15	4V430P-15
Fluid	Air (to be filtered by 40 µm filter element)				
Acting	Internal pilot or external pilot				
Port size [Note1]	In=Out=Exhaust=1/2"				
Orifice size	50.0mm <sup>2</sup> (Cv = 2.79)		30.0mm <sup>2</sup> (Cv = 1.68)		
Valve type	5 port 2 position		5 port 3 position		
Operating pressure	0.15~0.8MPa(21~114psi)				
Proof pressure	1.2MPa(175psi)				
Temperature	-20~70°C				
Material of body	Aluminum alloy				
Lubrication [Note2]	Not required				
Max. frequency [Note3]	3 cycle/sec				
Weight (g)	590	720	770		

**Sembol / Symbol**

**Ürün Özelliği / Product Feature**

1. Pilot-oriented mode: Internal pilot or external pilot.
2. Structure in sliding column mode: good tightness and sensitive reaction.
3. Three position solenoid valves have three kinds of central function for your choice.
4. Double control solenoid valves have memory function.
5. Internal hole adopts special processing technology which has little attrition friction, low start pressure and long service life.
6. No need to add oil for lubrication.
7. It is available to form integrated valve group with the base to save installation space.
8. Affiliated manual devices are equipped to facilitate installation and debugging.
9. Several standard voltage grades are optional.

[Note1] PT thread, G thread and NPT thread are available.

[Note2] Once lubricated air is used, continue with same medium to optimise valve life span. Lubricants like ISO VG32 or equivalent are recommended.

[Note3] The maximum actuation frequency is in the no-load state.

**Bobin Özellikleri / Coil Specification**

Item	specification				
Standard voltage	AC220V	AC110V	AC24V	DC24V	DC12V
Scope of voltage	AC: ±15% DC: ±10%				
Power consumption	4.5VA	4.5VA	5.0VA	3.0W	3.0W
Protection	IP65(DIN40050)				
Temperature classification	B Class				
Electrical entry	Terminal, Grommet				
Activating time	0.05 sec and below				

**Sipariş Kodu / Ordering Code**

 4V 4 10 15 A □ □  
 ① ② ③ ④ ⑤ ⑥ ⑦

① Model	② Code	③ Valve type	④ Port size	⑤ Voltage	⑥ Electrical entry	⑦ Thread type
4V: Solenoid valve (5/2, 5/3 way)	4: 400 Series	10: Single solenoid 5/2 way 20: Double solenoid 5/2 way 30C: Double solenoid 5/3 way closed center 30E: Double solenoid 5/3 way exhaust center 30P: Double solenoid 5/3 way pressure center	15: 1/2"	A: AC220V B: DC24V C: AC110V E: AC24V F: DC12V	Blank: Terminal I: Grommet	Blank: PT G: G T: NPT

Please refer to 76 for manifold specification and the order way.

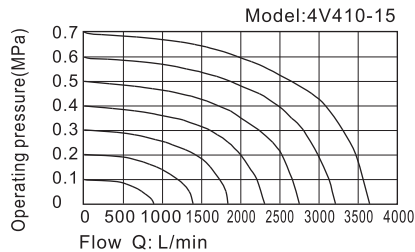
**Akış Şeması / Flow Chart**

**WINMAN Solenoid Valf (5/2 yollu, 5/3 yollu) / Solenoid Valve (5/2 way, 5/3 way)**

4V400 Serisi / 4V400 Series

**İç Yapı / Inner Structure**

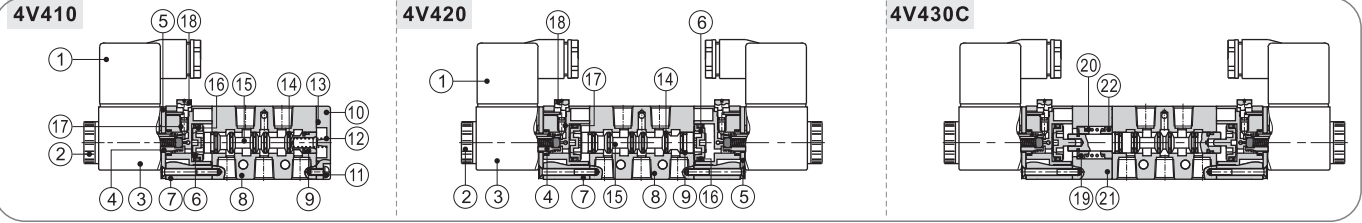

No.	Item	No.	Item	No.	Item	No.	Item	No.	Item	No.	Item	No.	Item	No.	Item	No.	Item	No.	Item		
1	Connector	3	Coil	5	Fixed plate	7	Pilot kit	9	Wear ring	11	Fixed screw	13	Bottom cover gasket	15	Spool	17	Override spring	19	Spring holder	21	Side cover
2	Coil net	4	Armature	6	Piston	8	Body	10	Bottom cover	12	Spool spring	14	Spool O-ring	16	Piston O-ring	18	Manual override	20	Return spring	22	Spring holder

**Boyutlar / Dimensions**

**4V410(Terminal)**

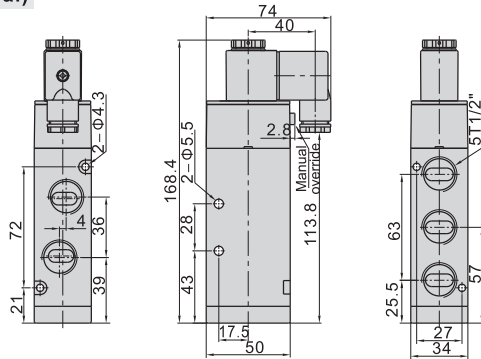

**4V410(Grommet)**

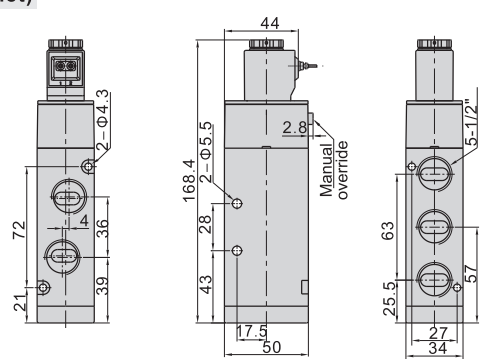

**4V420(Terminal)**

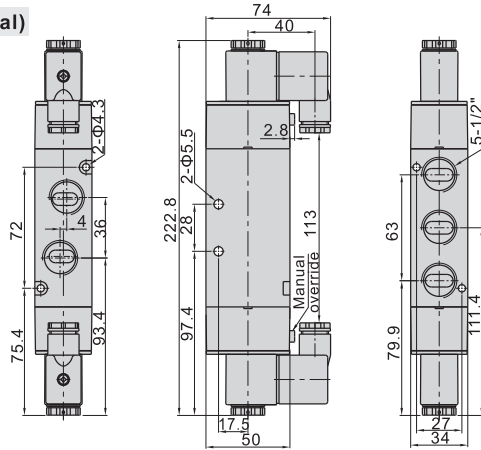

**4V420(Grommet)**

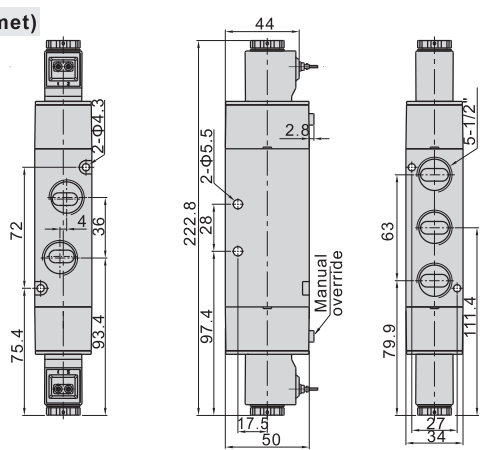

**4V430(Terminal)**

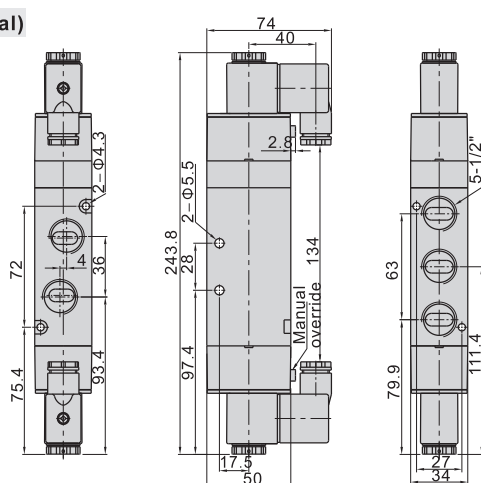

**4V430(Grommet)**

