

40 Ω - 10 Ω SERİLERİ / SERIES

Elektro Hidrolik Oransal Emniyet Valfleri ve Akış Kontrol Valfleri

PROPORTIONAL ELECTRO-HYDRAULIC RELIEF AND FLOW CONTROL VALVES

Bu basınç kontrol ve emniyet valfi enerji tasarrufu yapar ve gerekli miktarda enerjiyi kullanır.

Bu valfin pompa basıncını yüklemeye basıncına hitaben kontrol etmesinden ve aynı zamanda diferansiyel basıncı minimize etmesinden beri, az enerji sarfiyatı ve akış kontrolü sağlar.

Isı kontrol sisteminden bu yana bu sistem akış ısısına uyum sağlar.

This relief and flow control valve is an energy - saving valve that supplies the minimum pressure and flow necessary for actuator drive.

Since this valve controls the pump pressure by flowing the load pressure while keeping the differential pressure minimized, it serves as a low power - consumption energy - saving, metre -in, controlled flow control valve.

Further, since a temperature compensation function is incorporated, this valve provides consistent flow control without respect to the fluid temperature.

Oransal Pilot Emniyet Valfli
With Proportional Pilot Relief Valves

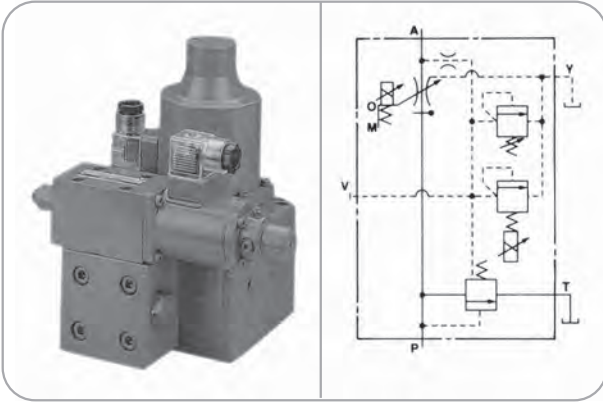

Oransal Pilot Emniyet Valfsiz
Without Proportional Pilot Relief Valves

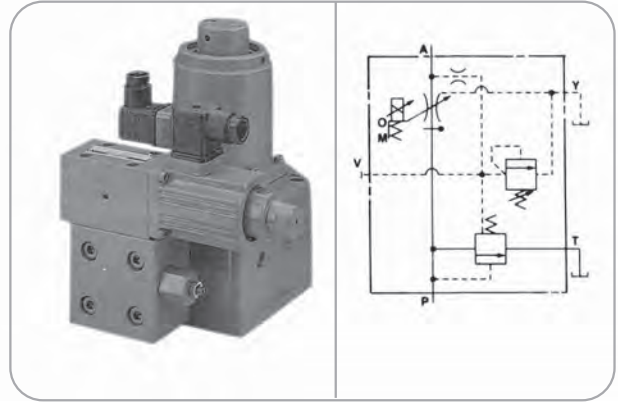

Oranlar / Ratings

Model No.		EFBG-03-125	EFBG-06-250	EFBG-10-500	
Tanımlama / Description					
Maks. Çalışma Basıncı Max. Operating Pressure	bar (PSI)	250 (3600)	250 (3600)	250 (3600)	
Maks. Debi Max. Flow	ℓ / min (U.S.GPM)	125 (33)	250 (66)	500 (133)	
Metred Flow Adjustment Range	Basınç Ayar Aralığı ℓ / min (U.S.GPM)	1-125 (.26-33)	2.5-250 (.66-66)	5-500 (1.32-132)	
Akış Kontrolleri Flow Controls	Akım / Rated Current	mA	680	580	700
	Bobin Direnci / Coil Resisitance	Ω	43.5	43.5	43.5
	Basınç Farkı / Differential Press.	bar (PSI)	6 (85)	7 (100)	9 (130)
	Histerez / Hysteresis		Less than 7 %	Less than 7 %	Less than 7 %
	Süreklilik / Repeatability		1 %	1 %	1 %
Basınç Kontrolleri Pressure Controls	Basınç Ayar Aralığı Press. Adj. Range	*2 bar (PSI)	C: 14 -140 (200-2000) H: 14-210 (200-3000)	C: 15 -140 (215-2000) H: 15-210 (215-3000)	C: 16 -140 (230-2000) H: 16-210 (230-3000)
	Akım / Rated Current	mA	C: 710 H: 770	C: 690 H: 730	C: 690 H: 690
	Bobin Direnci / Coil Resisitance	Ω	10	10	10
	Histerez / Hysteresis		Less than 3 %	Less than 3 %	Less than 3 %
	Süreklilik / Repeatability		1 %	1 %	1 %
Kütle / Mass	Kg (lbs)	16 kg	30 kg	60 kg	

*1 Basınç kontrol oranları, oransal emniyet valfine uygun yapılmıştır.

*2 Oransal emniyetsiz valflerin basınç ayar aralığı minimum basınca göre ayarlanır. 250 bar

*1 The rating for pressure controls is applied to models with proportional pilot relief valve. (Ex. EFBG - 03 -125-C-*15)

*2 Pressure adjustment range of the valves without preproportional pilot relief valves is from a minimum adjustable pressure to 250 bar (360 PSI).

SİPARİŞ KODU / ORDERING CODE

EFB G 03 125 C 10

Dizayn No. / Design No.

Oransal Emniyet Valfli Basınç Ayar Aralığı
With Proportional Pilot Relief Valve
Pres. adj. Ranges.
C: 14 - 140 Bar
H: 14 - 210 Bar
Kod Yoksa / None: Without Proportional Pilot Relief Valve

Maks. Debi / Max. Metering Flow
125: 125 l / min
250: 250 l / min
500: 500 l / min

Valf Boyutu / Valve Size: 03., 06. 10

Bağlama Tipi / Type of Mounting
G: Alt Plaka Bağlantı / Sub - Plate Mounting

Seri No. / Series No.
Elektro - Hidrolik Oransal Emniyet ve Basınç Kontrol Valfi
EFB: Electro - Hydraulic Proportional Relief and Flow Control Valve

ÖLÇÜLER / DIMENSIONS

EFBG - 03 - 125 - C_H - 10

BİRİM / UNIT : MM (INCHES)

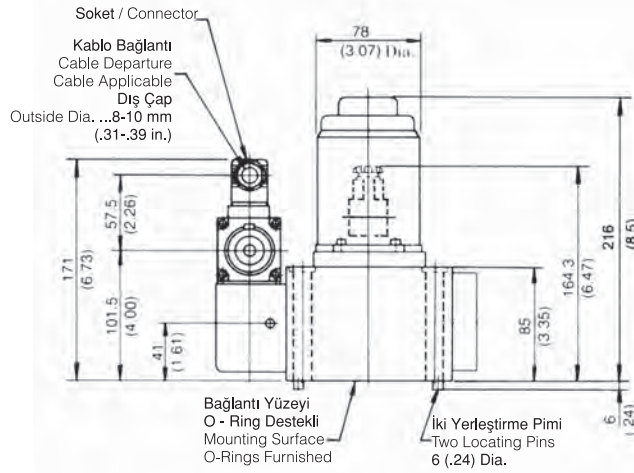
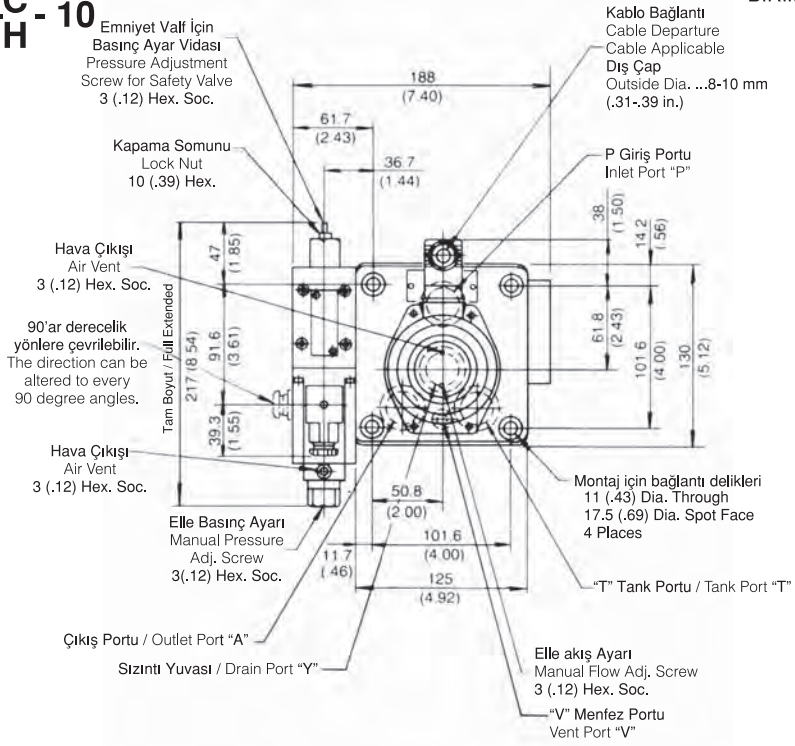

Mass 16 kg
(35.3 lbs)

EFBG - 03 - 125 - 10

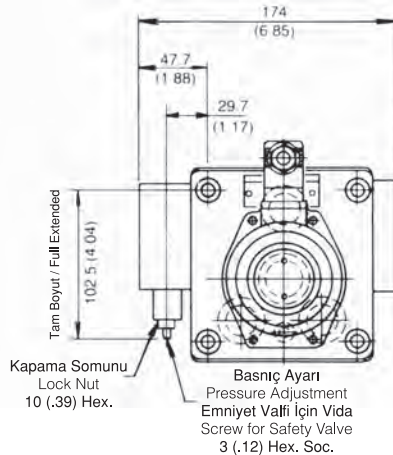

Mass 14 kg (30.9 lbs)

Diğer ölçüleri için ilgili sayfalara bakınız. / For other dimensions, please refer to the models above.

ÖLÇÜLER / DIMENSIONS

EFBG - 06 - 250 - C - H - 10

BİRİM / UNIT : MM (INCHES)

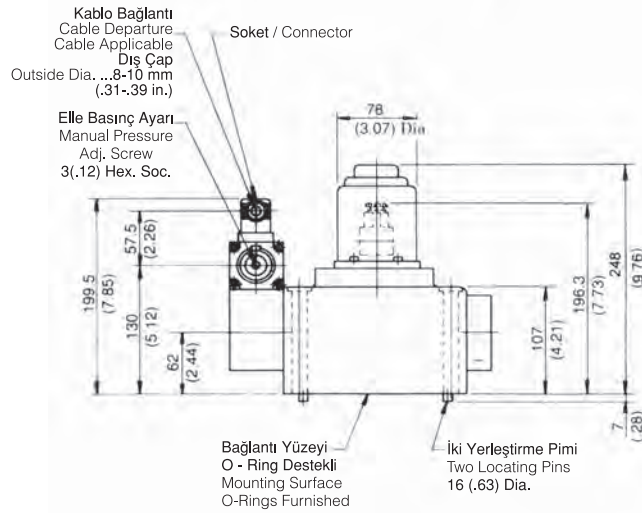
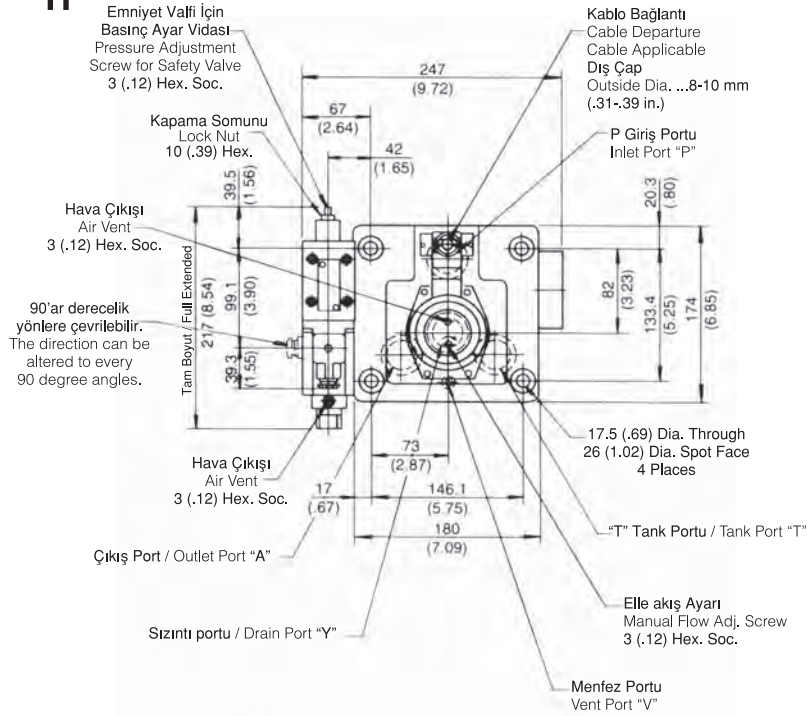

Mass 30 kg
(66.1 lbs)

EFBG - 06 - 250 - 10

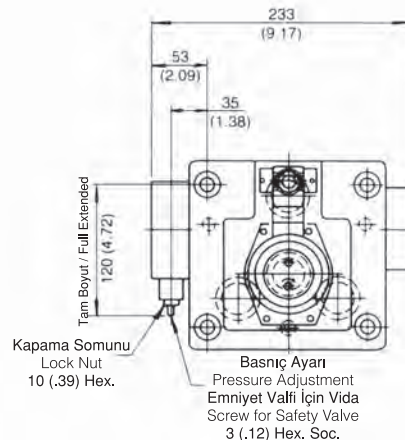

Mass 28 kg (61.7 lbs)

Diğer ölçüleri için ilgili sayfalara bakınız.
For other dimensions, please refer to the models above.

ÖLÇÜLER / DIMENSIONS

BİRİM / UNIT : MM (INCHES)

EFBG - 10 - 500 - C H - 10

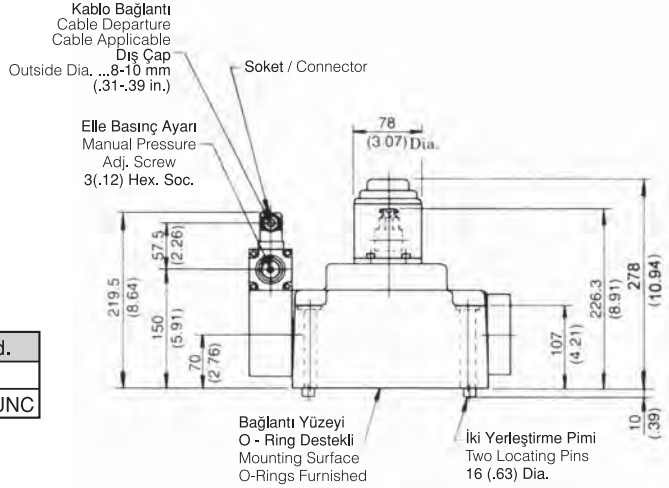
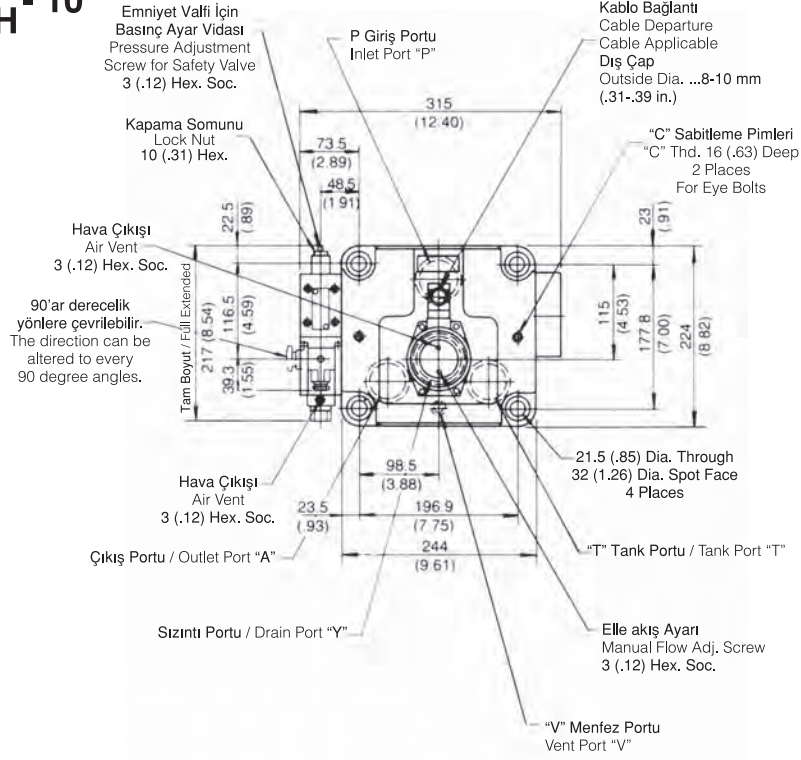

Model Numbers	"C" Thd.
EFBG - 10 - 500 - *-15	M8
EFBG - 10 - 500 - *-16	5/16-18 UNC

Mass 60 kg
(132.2 lbs)

EFBG - 10 - 500 - 10

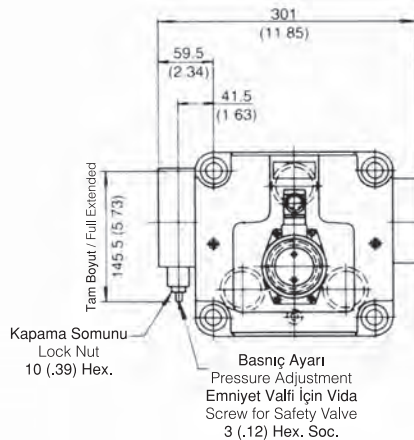

Mass 58 kg (127.8 lbs)

Diğer ölçüleri için ilgili sayfalara bakınız.
For other dimensions, please refer to the models above.

ÖLÇÜLER / DIMENSIONS

EFBGM-03Y/03Z-10

BİRİM / UNIT : MM (INCHES)

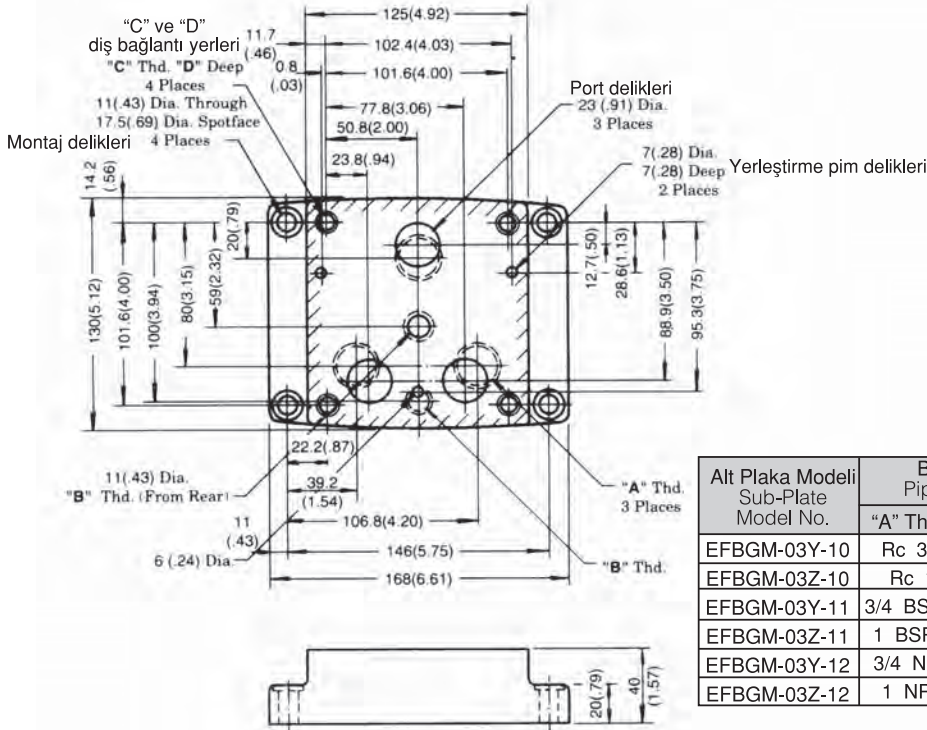

Alt Plaka Modeli Sub-Plate Model No.	Boyutlar Piping Size		"C" Thd.	D
	"A" Thd.	"B" Thd.		
EFBGM-03Y-10	Rc 3/4	Rc 1/4	M 10	18(.71)
EFBGM-03Z-10	Rc 1			
EFBGM-03Y-11	3/4 BSP.F	14 BSP.F	M 10	18(.71)
EFBGM-03Z-11	1 BSP.F			
EFBGM-03Y-12	3/4 NPT	1/4 NPT	3/8-16 UNC	21(.83)
EFBGM-03Z-12	1 NPT			

EFBGM-06X/06Y-10

Alt Plaka Model Sub-plate Model No.	Ölçüler / Dimensions mm (IN.)		
	B	C	D
EFBGM-06X	107 (4.21)	45 (1.77)	35 (1.38)
EFBGM-06Y	95 (3.74)	60 (2.36)	40 (1.57)

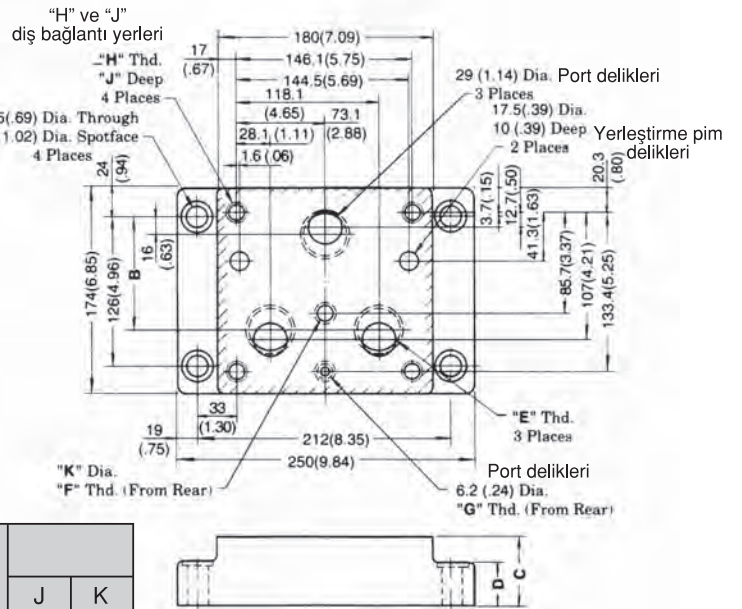

Alt Plaka Modeli Sub-Plate Model No.	Boyutlar Piping Size			"H" Thd.	J	K
	"E" Thd.	"F" THD.	"G" THD.			
EFBGM-06X-10	Rc 1	Rc 3/8	Rc 1/4	M16	30 (1.18)	14 (.55)
EFBGM-06Y-10	Rc 1-1/4					
EFBGM-06X-11	1 BSP.F	3/8 BSP.F	1/4 BSP.F	M16	30 (1.18)	15.2 (.60)
EFBGM-06Y-11	1-1/4 BSP.F					
EFBGM-06X-12	1 NPT	3/8 NPT	1/4 NPT	5/8-11 UNC	35 (1.18)	14 (.55)
EFBGM-06Y-12	1-1/4 NPT					

ÖLÇÜLER / DIMENSIONS

EFBGM-03Y/03Z-10

BİRİM / UNIT : MM (INCHES)

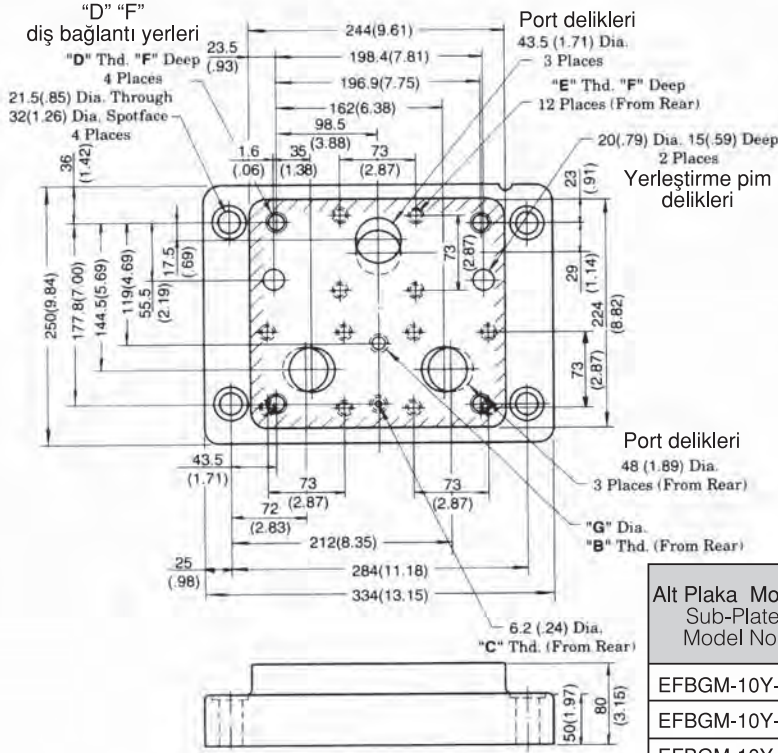

Alt Plaka Modeli Sub-Plate Model No.	Boyutlar Piping Size	
	"B" Thd.	"C" Thd.
EFBGM-10Y-10	Rc 3/8	Rc 1/4
EFBGM-10Y-11	3/8 BSP.F	1/4 BSP.F
EFBGM-10Y-12	3/8 NPT	1/4 NPT

Alt Plaka Modeli Sub-Plate Model No.	"D" Thd.	"E" Thd.	mm (IN.)	
			F	G
EFBGM-10Y-10	M20	M16	32 (1.26)	11 (.43)
EFBGM-10Y-11			15.2(.60)	
EFBGM-10Y-12	3/4-10 UNC	5/8-11 UNC	34 (1.34)	14 (.55)

GİRİŞ AKIMI-DEBİ / INPUT VS FLOW

