



TECHMAN
ROBOT



SMART
SIMPLE
SAFE

Industrial 4.0 enabled

Highly flexible deployment
and quick job change

Low automation and maintenance costs



Techman Robot



Techman Robot



www.facebook.com/tmrobot/



Techman_Robot



Techman_Robot



@Techmanrobot



4F, No.188 Wenhua 2nd Rd., Guishan Dist.Taoyuan City, 33383, Taiwan
TEL: +886-3328-8350 | www.tm-robot.com



Techman Robot is a registered trademark for Techman Robot Inc., which retains all the rights and interests of this trademark. The product information is for reference only, and Techman Robot Inc. is not responsible for any error or omission. Product data is subject to change without prior notice.

www.tm-robot.com



“We have decided to take a different path from the very beginning”

- Ho Shi-Chi, Chairman, Techman Robot. -

Our Company

Techman Robot entered the world of robotics in 2012 with the aim of revolutionising the market. Our robots combine 4 years' worth of research and development, utilising our 100+ team of experts focused on eliminating the traditional inconveniences often associated with industrial robotics. Guided by Chairman Ho Shi-Chi, we have managed to deliver the world's first collaborative robot with built-in vision as standard.

Quality, Innovation, and Service

As the world focused on industrial type robots that have been utilised for decades, Techman focused on investing in the development of collaborative robotics. Traditional industrial robots are often costly, require total safe guarding and are notoriously hard to programme and repurpose. utilising our extensive expertise and innovation from design, through to development and production, Techman have produced the number 1 choice in robotics for future industry 4.0 smart factories.

Our Future

Based on innovative science and technology, through our brand we hope to improve productivity and efficiency across a variety of applications and industries. In response for the global call for industry 4.0, IoT and cloud computing, Techman are invested in continuously creating industry innovations.





SMART

Built-in vision system

TM Robot is equipped with a built-in vision system, which integrates into both the hardware and software perfectly, whereas traditional add-on vision solutions to robotics are complicated, time consuming and costly to implement.

Masters in robot vision

Many standard robot vision functions are already built into our system: pattern matching, object localisation, image enhancement, bar code reading, colour recognition, etc. All these functions have been integrated into our remarkably easy-to-use user interface.

5 Minutes to achieve a visual pick & place task

Combining our smart vision system and our hand-guiding functions, everyone, even those without robotic programming experience, can achieve a visual pick & place task within 5 minutes.

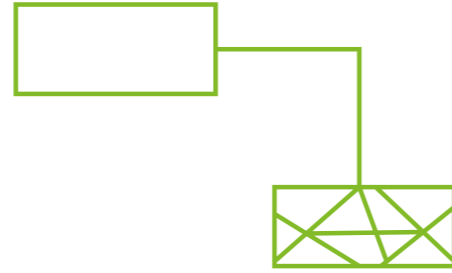

SIMPLE

Revolutionary user interface

No more coding! You can implement your automation task with our revolutionary simple-to-use user interface, an all-graphic flow chart based HMI. Users, even those without coding experience with industrial robots, can learn to use TM Robot easily and quickly. You can program every built-in vision function on the GUI. Furthermore, the traditional heavy umbilical wired pendant is gone. Our user interface can be operated on PCs, notebooks or tablets.

Use your hand

Another reason TM Robot is more simple to program than the other modern robots is our well designed hand-guiding functions with servo assist. You can lock selected axes to allow adjustment in defined planes and then fine tune the co-ordinates with easy editing of those co-ordinates within the programming package.

Easy to deploy

Because TM Robot is so simple to program, it is very easily deployed into different applications, reducing your time-to-production and saving your total cost in automation.



SAFE

Force limiting

TM Robot complies with the ISO 10218-1 & ISO/TS 15066 human-robot co-operation safety requirements for collaborative robots, allowing the robot to be programmed with both speed and force limits.

Safety is our priority

TM Robot is serious about safety in every aspect of the design of the whole robot system, through hardware, software and operational design.

Ergonomic design

TM Robots are physically designed to be safe to their surroundings, soft end caps and no sharp edges are all part of the collaborative experience.



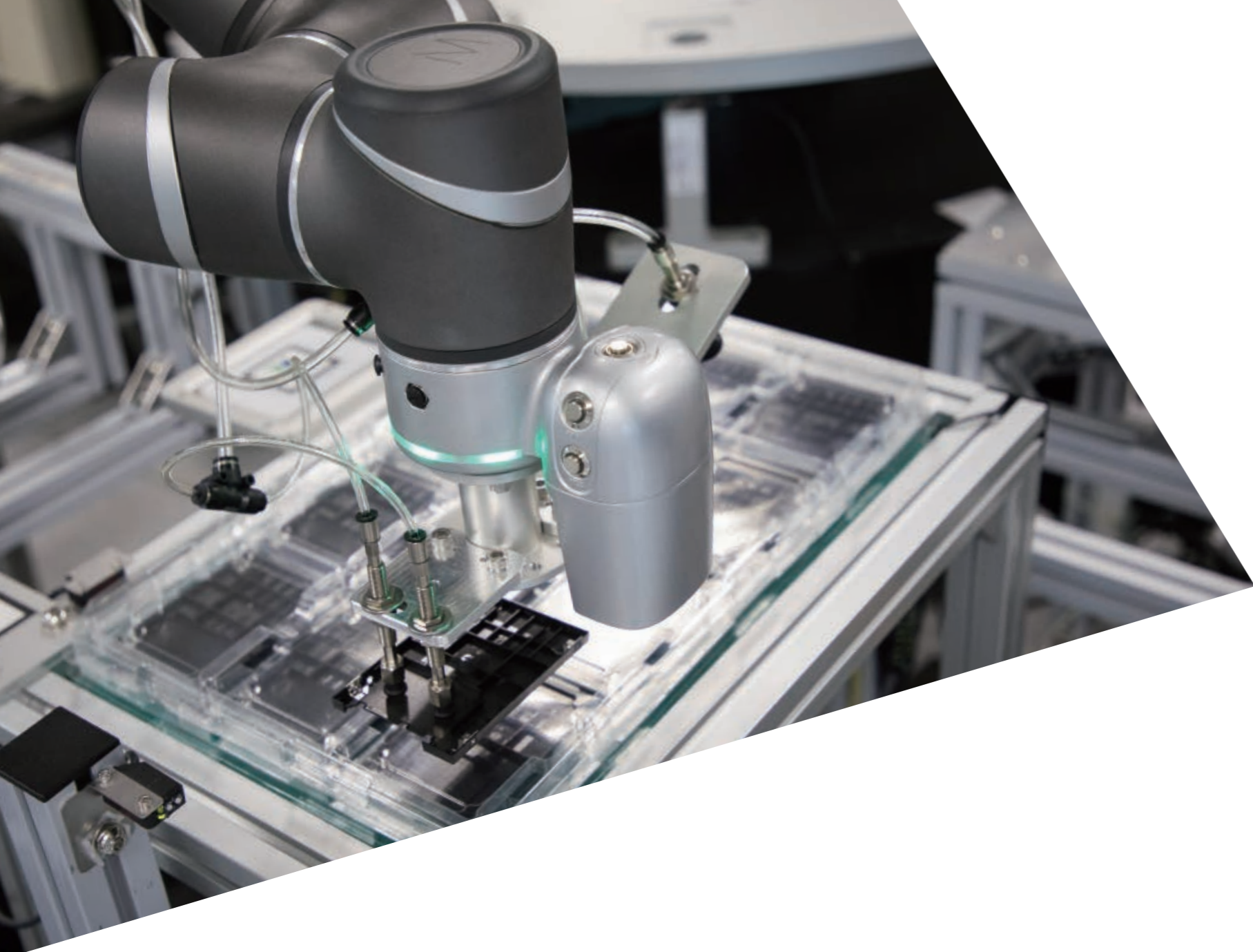

TM5

The most intelligent collaborative robot with built-in vision



The first choice for flexible automation applications

The TM5 collaborative robot features simple programming, innovative integrated vision capabilities together with the latest safety functionality, all leading to rapid deployment in a huge variety of applications. Having vision identification functionality completely integrated within the collaborative robot platform, provides an easy and intuitive way to achieve robot calibration to work piece or tooling, product selection, 1D or 2D barcodes and a host of other vision applications, delivering a true Industry 4.0 solution.

- Reach: 700mm, 900mm
- Payload: 6kg, 4kg

Industrial application:

- 3C industry
- Automobile industry
- Food industry
- Other

High Payload Series

Greater payload capability with increased reach

Featuring a payload capability greater than other collaborative robots on the market with a similar arm length, the TM12 and TM14 still remain simple, smart and safe. These robots are easy to operate and still offer rapid redeployment, reducing your automation and maintenance costs whilst increasing precision and production for various industries.

Built-in vision system

The TM built-in vision system offers template matching, item positioning, image enhancement, barcode identification and colour categorisation. All these functions have been integrated into our remarkably easy-to-use user interface for simple programming.



TM12

Strong load function + wide work area

- Reach: 1300mm
- Payload: 12kg
- Payload is greater than similar arm length collaborative robots on the market

Industrial application:

- Semiconductor industry
- Panel industry
- CNC industry
- Other

TM14

The highest load capability in the TM product series

- Reach: 1100mm
- Payload: 14kg

Industrial application:

- Semiconductor industry
- Panel industry
- CNC industry
- Other



TM Mobile Series

The ultimate solution for integrating collaborative robots with automated guided vehicles

TM5M, TM12M, TM14M

Highly flexible and compatible thanks to DC power design.

TM Robot's high performance mobile series utilise an inbuilt vdc supply, making them compatible with most brands of AGV/MR in the market today.

Built in vision for precision positioning

By utilising the "TM Landmark", the mobile robot can orientate itself within a 3D space, like an auto datum sequence, to multiple machine surfaces. This allows the TM-M robots to operate between two or more locations seamlessly. This solution is optimal for mobile stacking and machine tending applications.

SEMI S2 certified (Option)

Now with SEMI S2 certification for the semiconductor wafer industry, making the TM Robot of choice for automation transferring applications between different work stations.

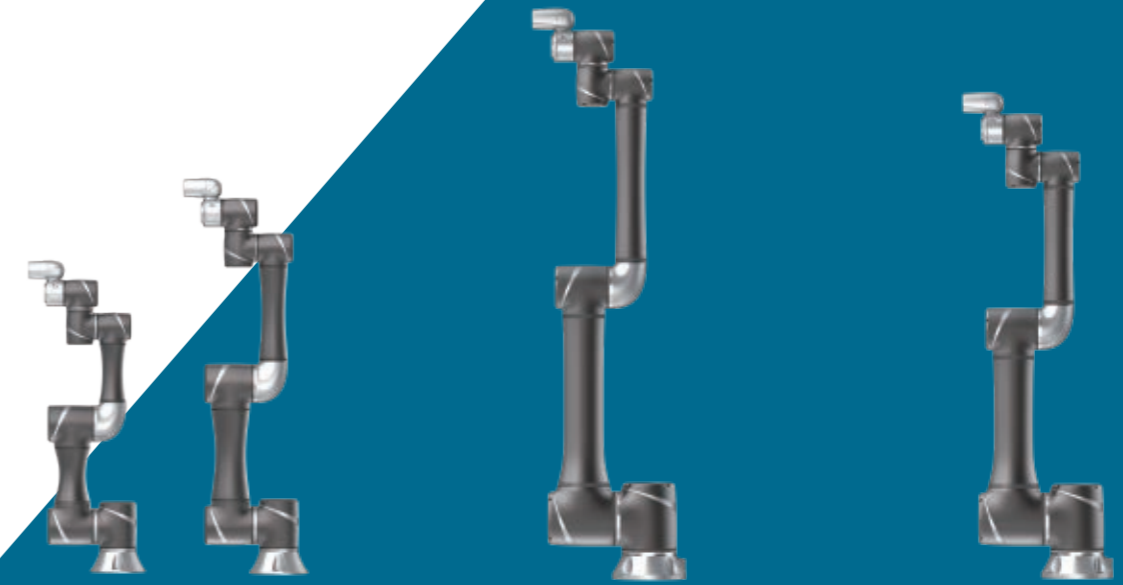

TM5M :
Applicable for electronic industry mobile assembly.

TM12M :
Applicable for mobile stacking and mobile Machine Tending.

TM14M :
Applicable for heavy load pickup/ placement and semiconductor wafer box automatic transfer.



What is the difference between the TM smart collaborative robot and traditional industrial robots?

Collaborative robots are designed to be safe to operate around people, working alongside their 'colleagues' without the need for additional safety precautions. Collaborative robots are very easy to program unlike traditional industrial robots that require advanced programming skills, cobots can be given work instructions without coding. TM's range of collaborative robots can achieve human-machine collaboration by combining its safe robotic technology, simple user interface and smart integrated vision system, significantly increasing efficiency and decreasing costs.

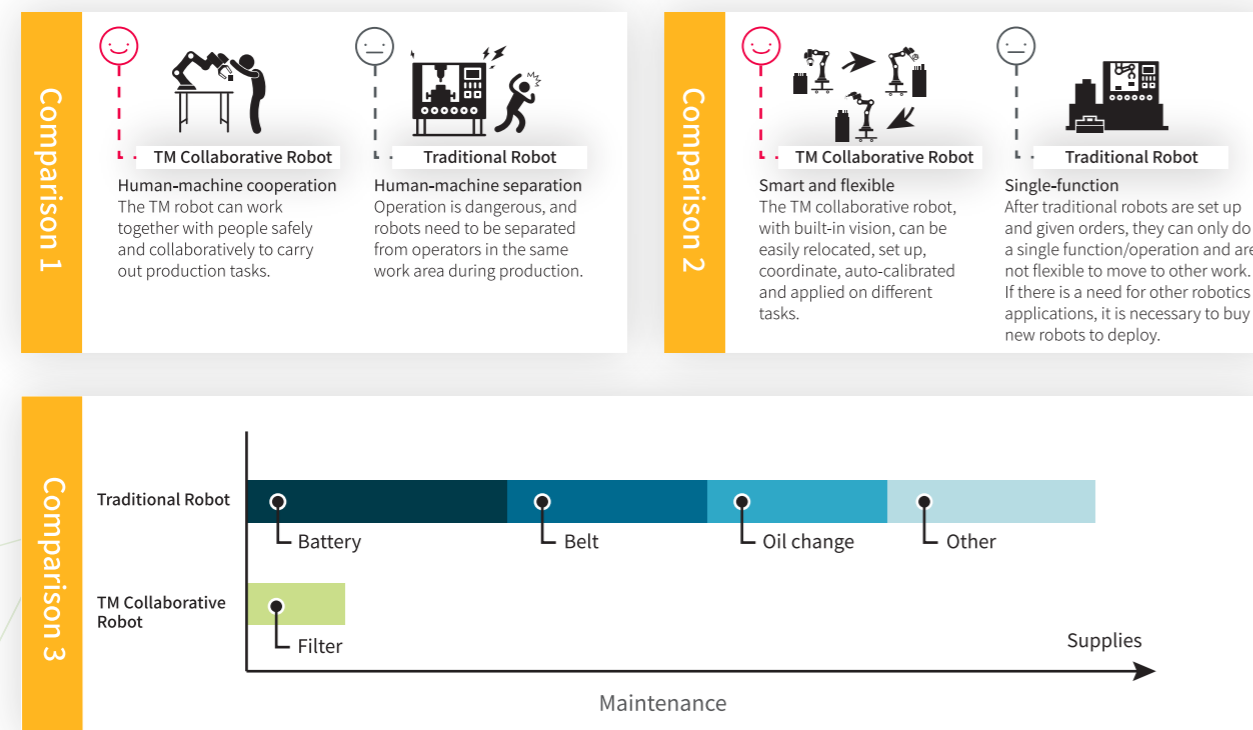

For reference only

TM Robot's industry applications

The ease of the TM collaborative robot operation means that it can be applied to various different industries, such as electronic assembly, metal processing, testing etc... TM's built-in vision function features such as shape matching, barcode & QR code reading, colour recognition, OCR etc are all easily configured from the integral robot design toolbox. Furthermore, The TM-M series are powered by DC supply, making them compatible with most brands of AGV's and mobile vehicles.

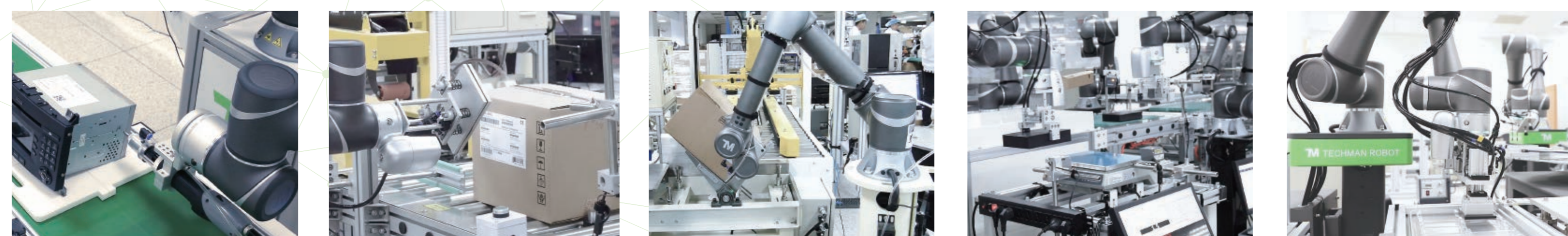
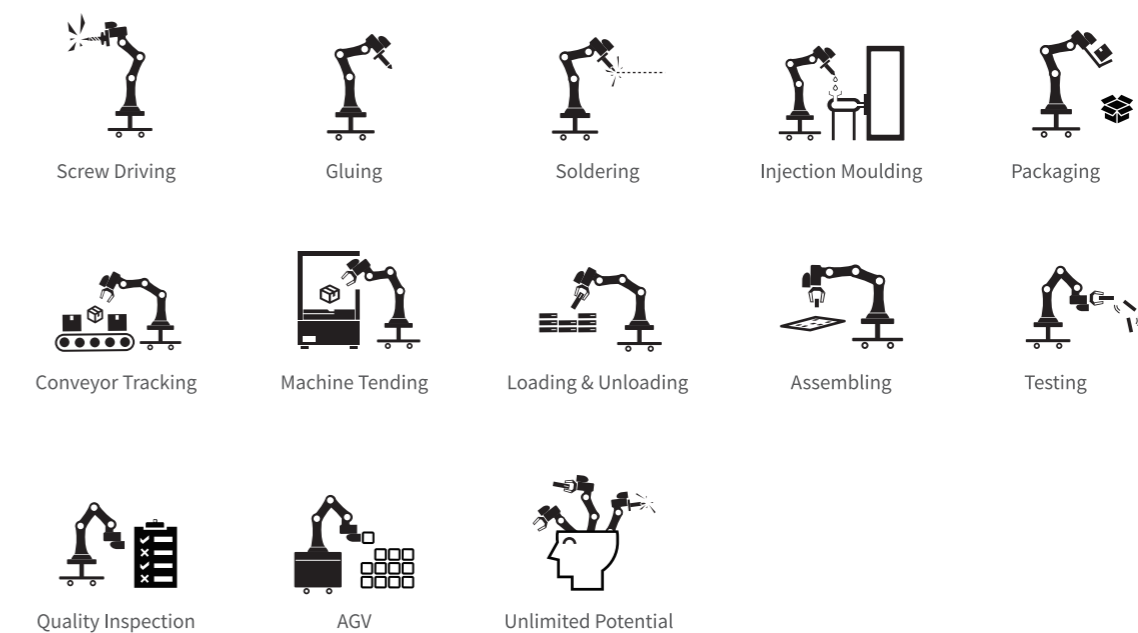

TMflow

Developed by Techman Robot, TMflow™ Is our Innovative flow-based robot editing software. Each function is shown as a different image and features intuitive click and drag methods. Users without coding experience of industrial robots can complete a visual pick & place program in as little as 5 minutes.

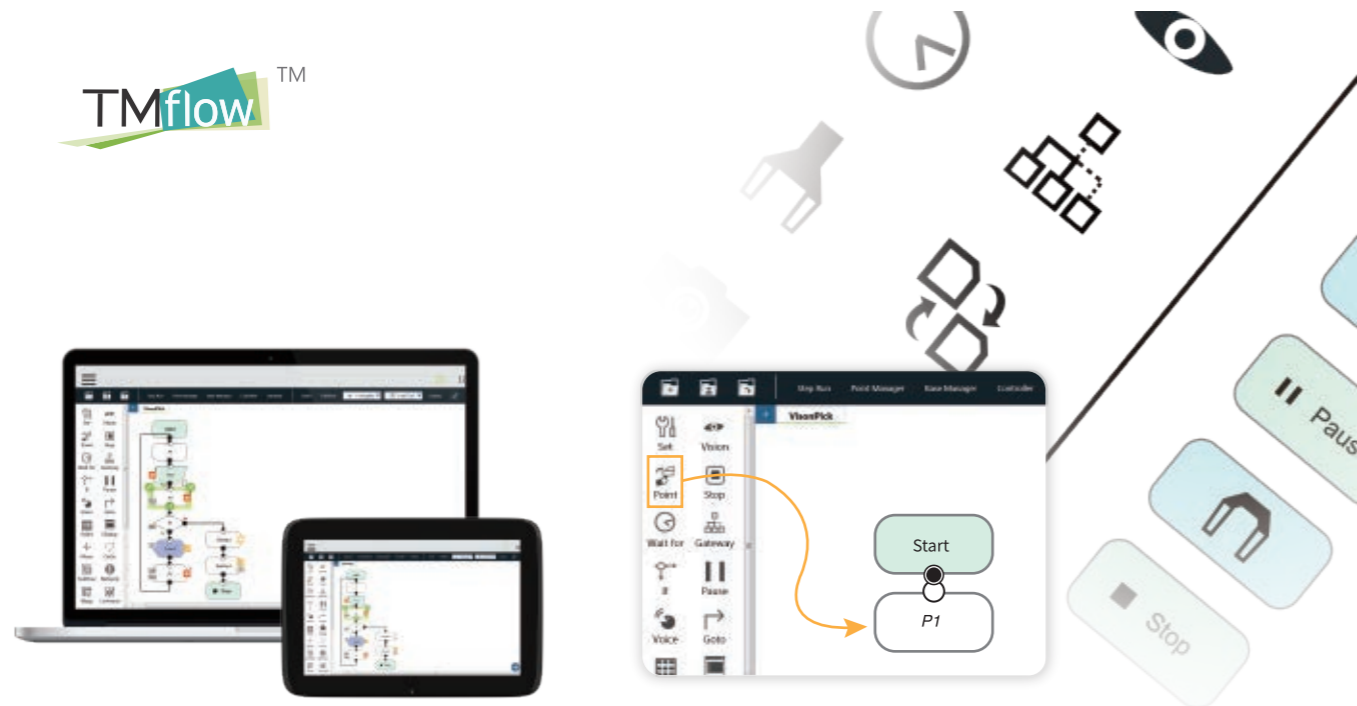

All-graphic procedure flow

Simply click and drag image to easily complete robot program editing

Smart Vision System

TM Robot Built in Vision system

Item detection module (Find)



Template matching (shape-based pattern matching): use the item's shape characteristics to find its location on the image.



Position alignment (fiducial-mark matching): use two points on the target for positioning



Template matching (image-based pattern matching): use the item's pixel value distribution to find its location on the image.



Irregular item detection (blob finder): use the item and background color difference to find the foreground item.

Image enhancement module (Enhance)



Contrast enhancement is used to adjust image contrast



Morphology can turn lines thicker or thinner, patch holes, or break apart lines



Image smoothing



Color plane extraction can extract specific color planes such as red, blue, green, or saturation



Image thresholding converts the image into black and white

Identify - Barcode/QR code module support 1-Dashboard, QR code and 2-D DataMatrix decoding



One dimension/two dimension barcode identification



Color identification

TM Plug&Play Solution

With the help of TM Plug&Play, TM Robots can connect to multiple robotic peripheral products available on the market. TM Plug&Play is available as standard allowing users to easily integrate third party peripherals to the robot, considerably reducing time and cost.

Start to use within five minutes



Simple, efficient, and fast production line introduction

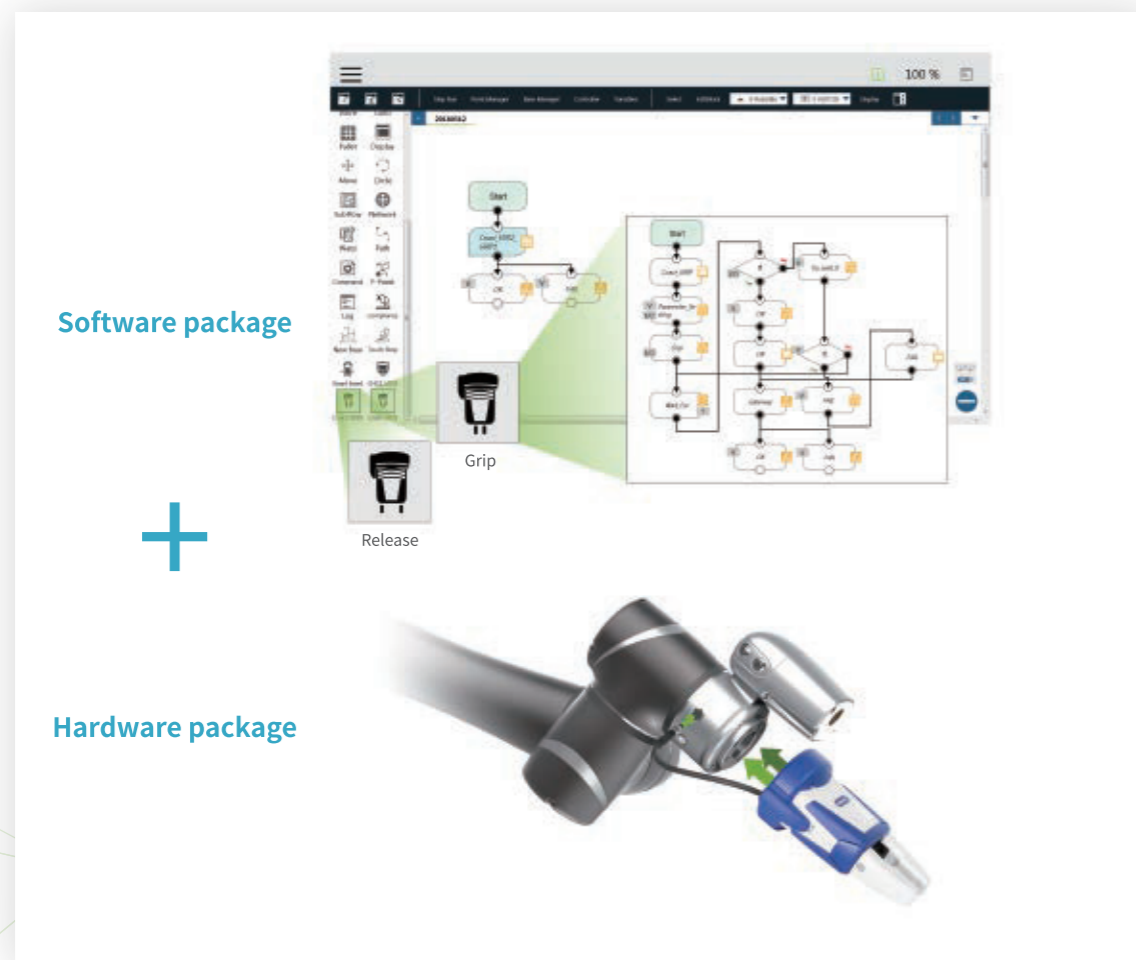

Screw Plug&Play example

Specification



Model	TM5-700	TM5-900	TM5M-700	TM5M-900
Weight	22.1kg	22.6kg	22.1Kg	22.6Kg
Payload	6kg	4kg	6kg	4kg
Reach	700mm	900mm	700mm	900mm
Typical Speed	1.1m/s	1.4m/s	1.1m/s	1.4m/s
Joint ranges	J1	+/- 270°		
	J2,J4,J5	+/- 180°		
	J3	+/- 155°		
	J6	+/- 270°		
Speed	J1~J2	180°/s		
	J3	180°/s		
	J4~J5	225°/s		
	J6	225°/s		
Repeatability	+/- 0.05 mm			
Degrees of freedom	6 rotating joints			
I/O ports	Control box		Tool conn.	
	Digital in	16	3/4(by Reginal Model)	
	Digital out	16	3/4(by Reginal Model)	
	Analog in	2	1	
	Analog out	1	0	
I/O power supply	24V 1.5A for control box and 24V 1.5A for tool			
IP classification	IP54(Arm)			
Power Consumption	Typical 220 watts			
Temperature	The robot can work in a temperature range of 0-50°C			
Power supply	100-240 VAC, 50-60 Hz		DC24V/48V/22~60V (by Reginal Model)	
I/O Interface	3×COM, 1×HDMI, 3×LAN, 4×USB2.0, 2×USB3.0, 1×VGA(by Reginal Model)			
Certification	CE(by Reginal Model), SEMI S2(Optional)			
Variation Models	X: without hand eye camera, SEMI: SEMI S2 certified			
Robot Vision				
Eye in Hand (Built in)	1.2M/5M pixels, color camera			
Eye to Hand (Optional)	Support Maximum 2 GigE cameras			



Model	TM12	TM14	TM12M	TM14M	
Weight	33.3Kg	32.6Kg	33.3Kg	32.6Kg	
Payload	12kg	14kg	12kg	14kg	
Reach	1300mm	1100mm	1300mm	1100mm	
Typical Speed	1.3m/s	1.1m/s	1.3m/s	1.1m/s	
Joint ranges	J1	+/- 270°			
	J2,J4,J5	+/- 180°			
	J3	+/- 166°	+/- 163°	+/- 166°	+/- 163°
	J6	+/- 270°			
Speed	J1~J2	120°/s			
	J3	180°/s			
	J4~J5	180°/s	150°/s	180°/s	150°/s
	J6	180°/s			
Repeatability	+/- 0.1 mm				
Degrees of freedom	6 rotating joints				
I/O ports	Control box		Tool conn.		
	Digital in	16	4		
	Digital out	16	4		
	Analog in	2	1		
	Analog out	1	0		
I/O power supply	24V 1.5A for control box and 24V 1.5A for tool				
IP classification	IP54				
Power Consumption	Typical 300 watts				
Temperature	The robot can work in a temperature range of 0-50°C				
Power supply	100-240 VAC, 50-60 Hz		DC 22V~60V		
I/O Interface	3×COM, 1×HDMI, 3×LAN, 4×USB2.0, 2×USB3.0				
Certification	CE, SEMI S2(Optional)				
Variation Models	X: without hand eye camera, SEMI: SEMI S2 certified				
Robot Vision					
Eye in Hand (Built in)	1.2M/5M pixels, color camera				
Eye to Hand (Optional)	Support Maximum 2 GigE cameras				

Operating Area

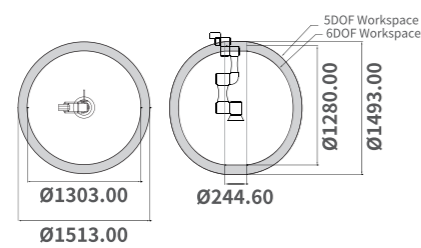

TM5-700, TM5M-700

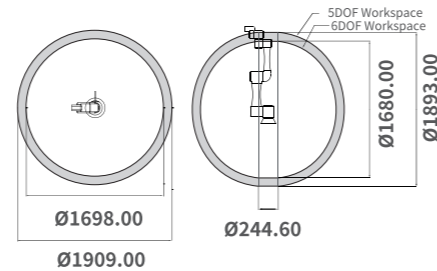

TM5-900, TM5M-900

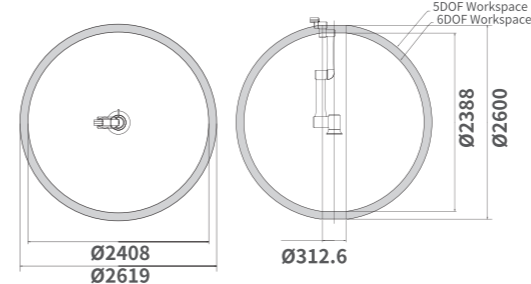

TM12, TM12M

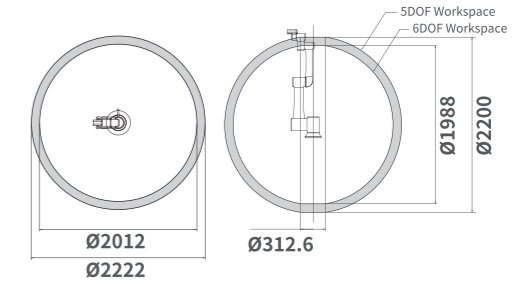

TM14, TM14M