

## ÇİFT ETKİLİ KARŞI DENGE VALFLER DOUBLE ACTING OVERCENTER VALVES

## VBCD

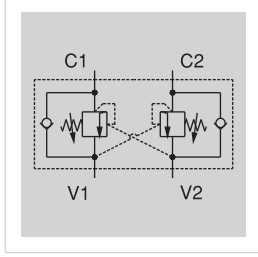

VBCD çift etkili karşı denge valfleri hem yükün iniş kontrolünü sağlar, hem de çift etkili silindiri durdurur.

The double acting overcenter valves type VBCD allow both the descent control of a load and the stop of a double acting cylinder

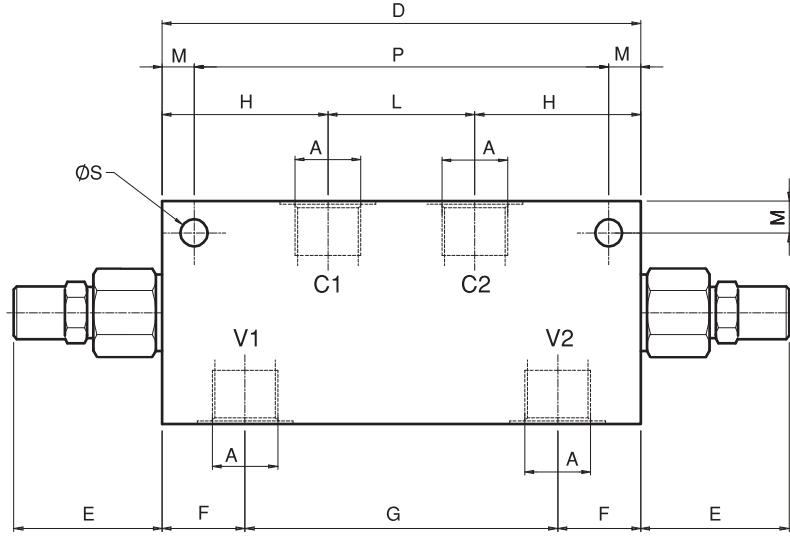
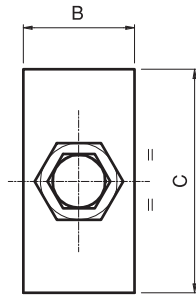

### TEKNİK ÖZELLİKLER / FEATURES

Kod Code	A	Max. Debi Max flow l/min	Max. Basınc Max pressure bar	B	C	D	E	F	G	H	L	M	N	Pilot Oranı Pilot ratio	Ağırlık Weight Kg
VBCD140	BSPP 1/4	30	210	30	60	150	46,5	26	98	52	46	10	6,5	1:4,25	0,62
VBCD380	BSPP 3/8	40		30	60	150	46,5	26	98	52	46	10	6,5		0,58
VBCD120	BSPP 1/2	60		35	70	150	46,5	26	98	52	46	10	8,5		0,60

### SİPARİŞ KODU / ORDERING CODE

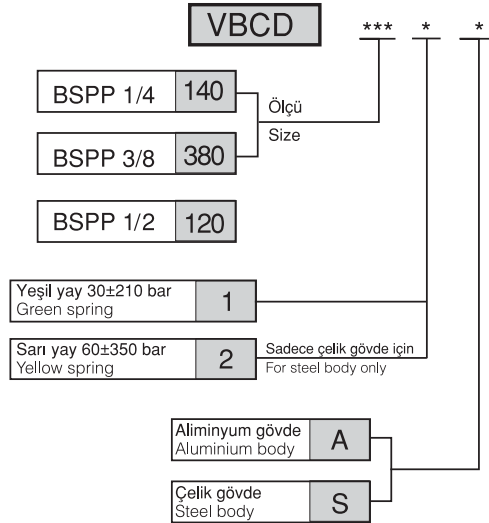

### BASINÇ DÜŞÜŞÜ / PRESSURE DROP

