

Power clamp cylinder -WGK SERIES

WGK Series

Compendium of WGK Series

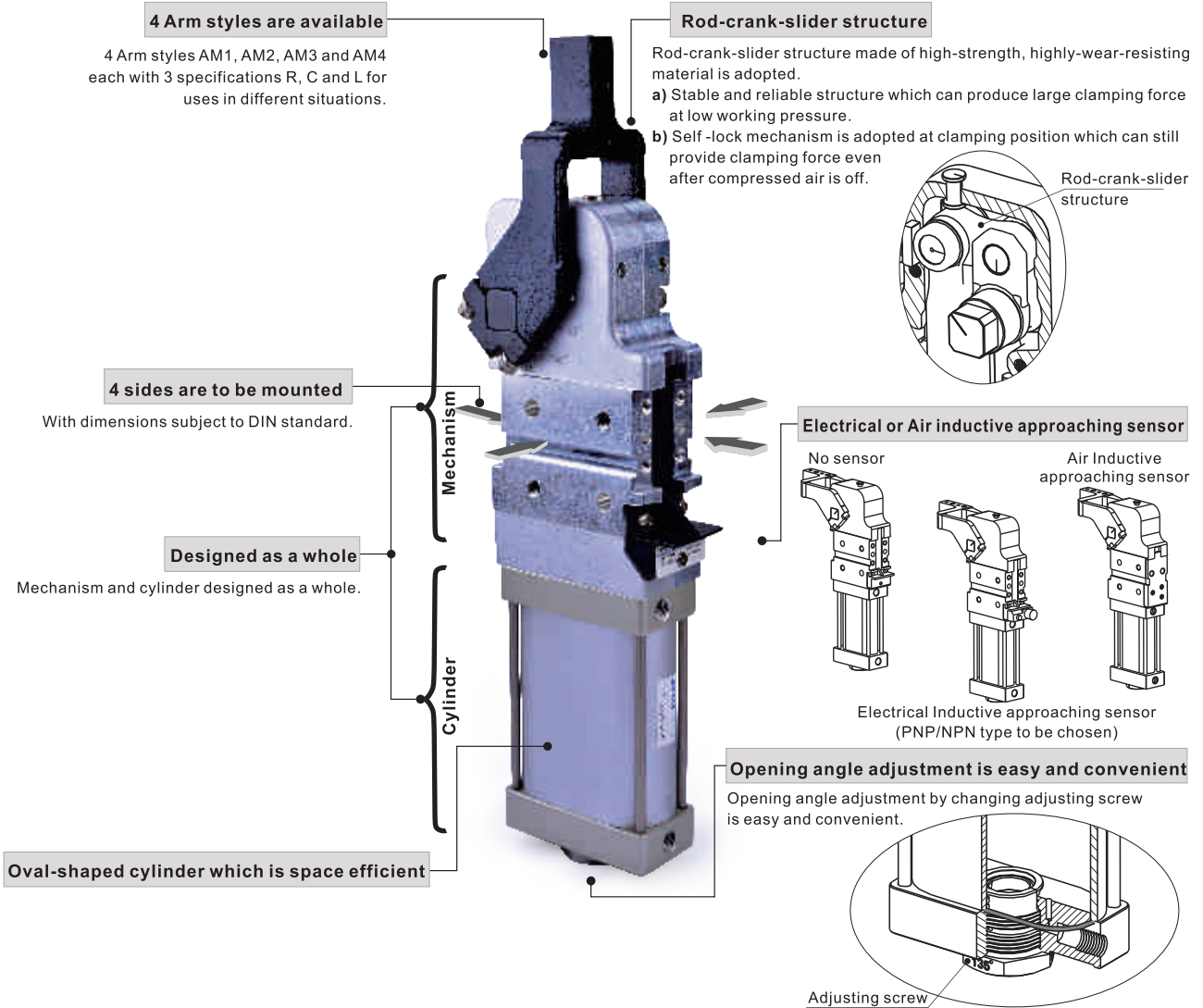

Application



Power clamp cylinder - WGK SERIES

WGK Series- Standard type



Model	WGK40	WGK50	WGK63	WGK80
Output torque (0.5 MPA)	120N.m	160N.m	380N.m	800N.m
Acting Type	Double acting			
Fluid	Air (to be filtered by 40 μ m filter element)			
Operating pressure	0.3~0.8 MPa (43 ~ 116 psi)			
Proof pressure	1.2 MPa (175 psi)			
Temperature	-10 ~60 °C			
Opening angle	15°/30°/45°/60°/75°/90°/105°/120°/135°			
Min. opening and closure time	1 second clamping, 1 second opening			
Position sensing	Inductive approaching sensor			
Cushion type	Air buffer			
Weight (135°) ①	2.2 kg	4.0 kg	5.5 kg	13.0 kg
Port size ②	1/8"		1/4"	

① This weight includes 15 mm offset clamping arm;
 ② PT thread , G thread and NPT thread are available.

Ordering Code

WGK 63 X 135 AM1R K

① ② ③ ④ ⑤ ⑥ ⑦

① Model	② Clamping arm position	③ Bore size	④ Opening angle	⑤ Clamping arm [Note2]	⑥ Sensor switch [Note3]	⑦ Thread type
WGK: Power clamp cylinder (Double acting)	Blank: horizontal 	40(circular)	15 30 45 60 75 90 105 120 135 [Note1]	Blank: No clamping arm	Blank: No sensor switch	Blank: PT G: G
	V: Vertical 			AM1: Offset 15mm 		
				AM3: Offset 45mm 		
				Blank: No clamping arm	K: With electrical sensor switch(PNP)	
				AM1: Offset 15mm 	KN: With electrical sensor switch(NPN)	
				AM3: Offset 45mm 	KA: With air sensor switch	
				AM2: Offset 15mm 		
				AM4: Offset 45mm 		

[Note1] Please refer to the right table for details of max. opening angle.

[Note2] Please refer to the drawing for detailed dimensions of clamping arm.

[Note3] K/KA type sensor switch can be ordered separately and please refer to relative contents.
 KA type sensor switch can't be ordered separately and 80 size no KA type.

Bore size	Arm position	Arm type	Maximum opening angle
40	horizontal	AM1	135°
		AM3	105°
	Vertical(V)	AM1	120°
		AM3	105°
50 63 80	horizontal	AM1、AM3 AM2、AM4	135°
	Vertical(V)	AM1、AM3 AM2、AM4	105°

Inner structure and material of major parts

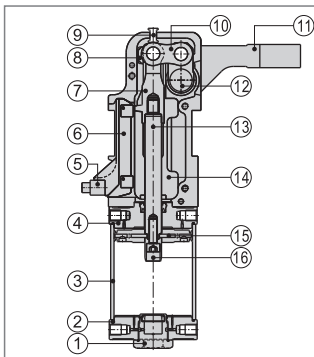

NO.	Item	Material
1	Adjusting screw	Free machining steel
2	Back cover	Aluminum alloy
3	Aluminum barrel	Aluminum alloy
4	Front cover	Aluminum alloy
5	Sensor switch	
6	Sensor switch fix	Plastic
7	Y knuckle	Alloy steel
8	Strengthen steel plate	Alloy steel
9	Retaining pin	Carbon steel
10	Connecting rod	Alloy steel
11	Clamping arm	Cast steel
12	Pivot	Alloy steel
13	Piston rod	Carbon steel
14	End cap	Aluminum alloy
15	Piston	NBR
16	Cushion body	Aluminum alloy

Power clamp cylinder - WGK SERIES

WGK Series- Standard type

How to select product

1. Please design appropriate fixture according to "Allowable Arm Load-Load Offset curve" diagram.

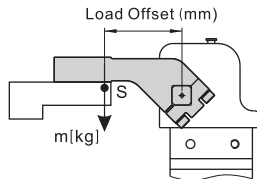

Bore size	Maximum load torque	
	1 second period	2 second period
40	2.2Nm	3.3Nm
50	4.5Nm	6.7Nm
63	6.0Nm	9.0Nm
80	8.0Nm	11.2Nm

S: distance from pivot point to center of mass of clamping arm
m: weight of clamping arm

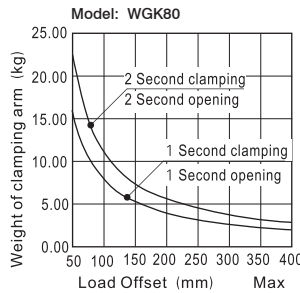
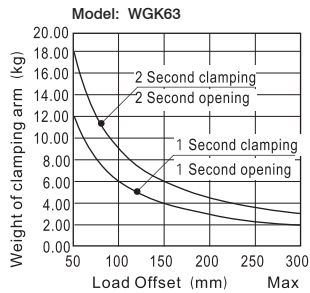
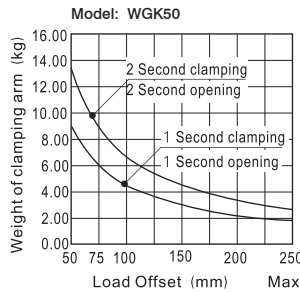
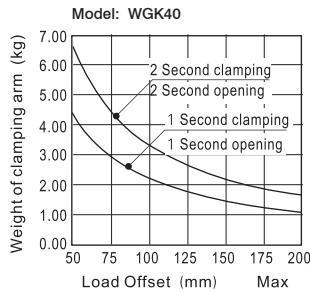

Attention: Please use with speed control valve.

2. Please choose appropriate clamping position according to "Torque-Clamping Arm Length curve" diagram.

Note: For clamping force is produced by elbow mechanism, maximum torque is only reached at final clamping arm position.

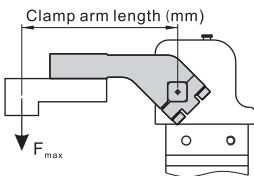

Bore size	Maximum holder torque
40	380Nm
50	800Nm
63	1500Nm
80	2500Nm

Bore size	Maximum clamp torque					
	0.3MPa	0.4MPa	0.5MPa	0.6MPa	0.7MPa	0.8MPa
40	72Nm	95Nm	120Nm	143Nm	167Nm	191Nm
50	99Nm	132Nm	165Nm	198Nm	230Nm	264Nm
63	230Nm	307Nm	384Nm	460Nm	537Nm	614Nm
80	482Nm	643Nm	803Nm	964Nm	1124Nm	1285Nm

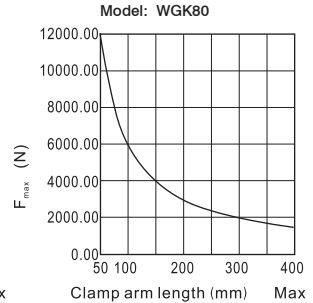
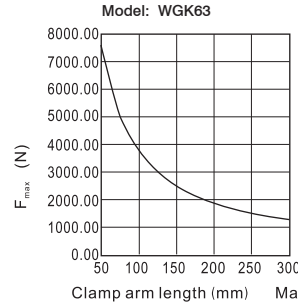
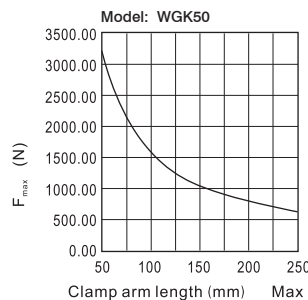
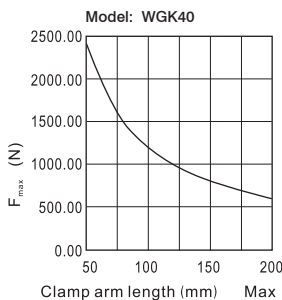

3. Please choose appropriate washer according to "Torque-Spacer thickness curve" diagram.

Note: Inserted washer exceeding maximum clamping torque position may lead to self-lock failure. Take safety issue into account when considering thickness of spacer inserted.

Besides, clamping arm length L represents distance from pivot point to clamping position. For distance from mounting base locating hole to pivot A, please refer to the following table.

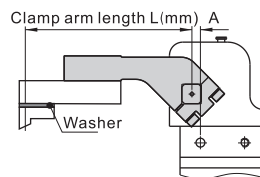

Bore size	A (mm)
40	12
50	10
63	10
80	15

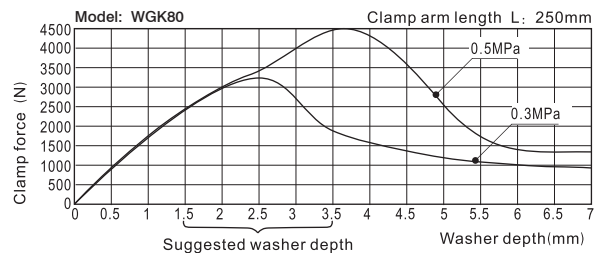
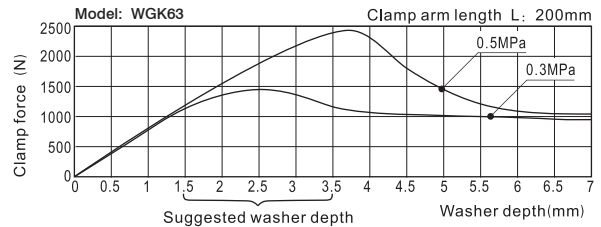
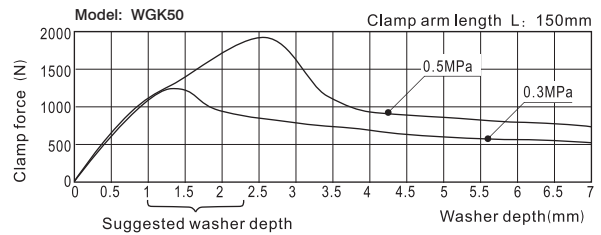
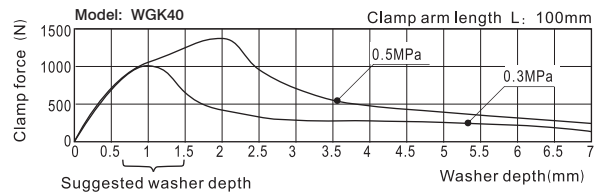

Power clamp cylinder - WGK SERIES

WGK Series- Standard type

Dimensions

WGK40AM1

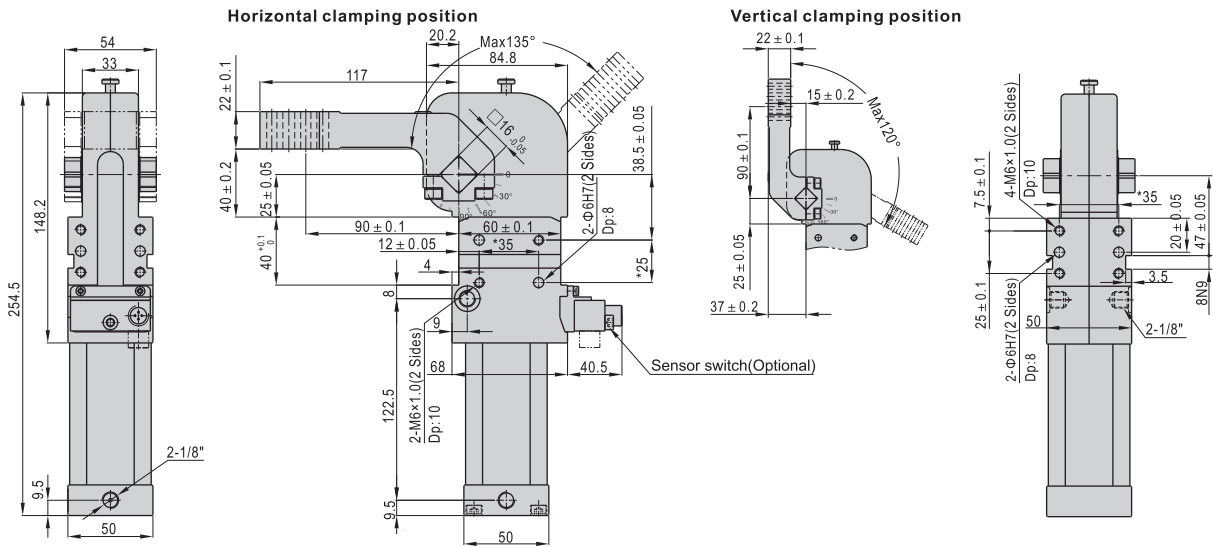

With * dimension: pin hole position tolerance: ±0.02. Thread hole position tolerance: ±0.1.

WGK40AM3

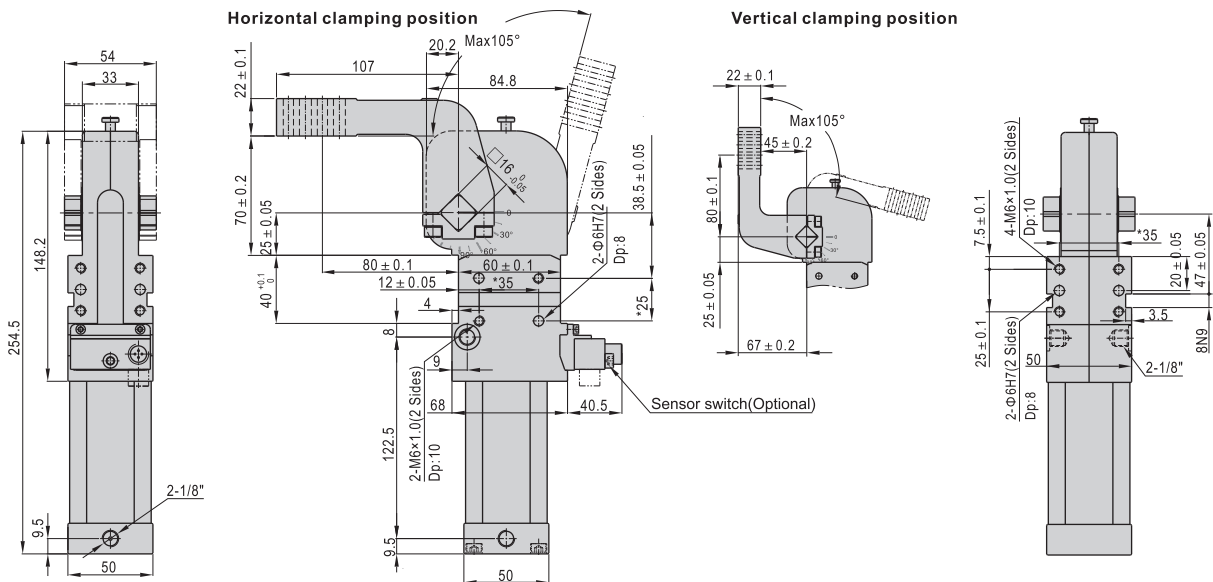

With * dimension: pin hole position tolerance: ±0.02. Thread hole position tolerance: ±0.1.

Power clamp cylinder - WGK SERIES

WGK Series- Standard type

Dimensions

WGK50AM1(2)

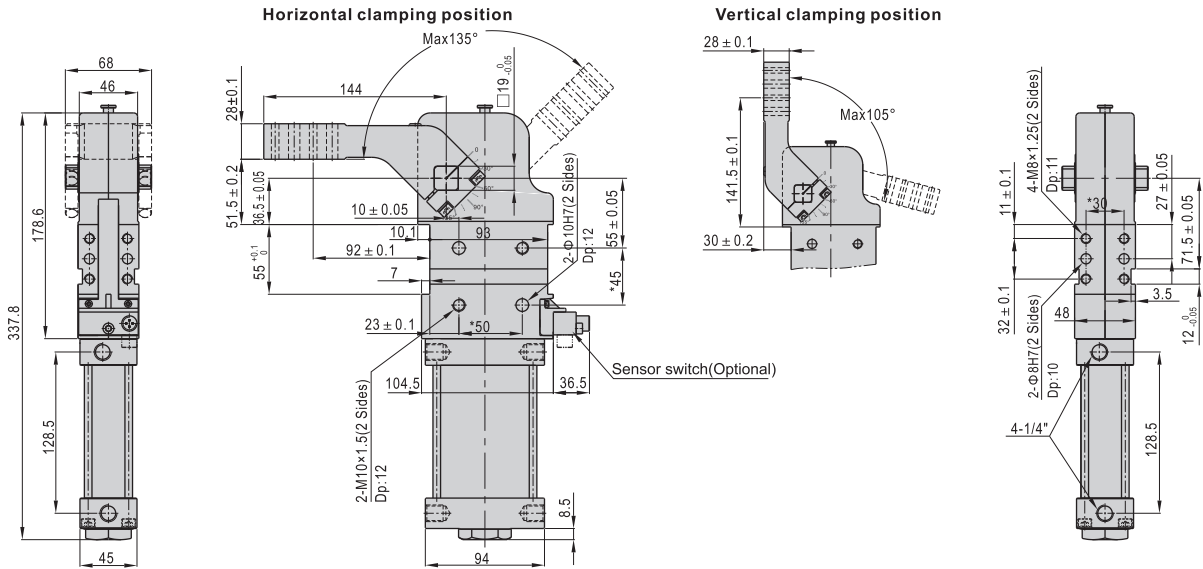

With * dimension: pin hole position tolerance: ± 0.02 . Thread hole position tolerance: ± 0.1 .

WGK50AM3(4)

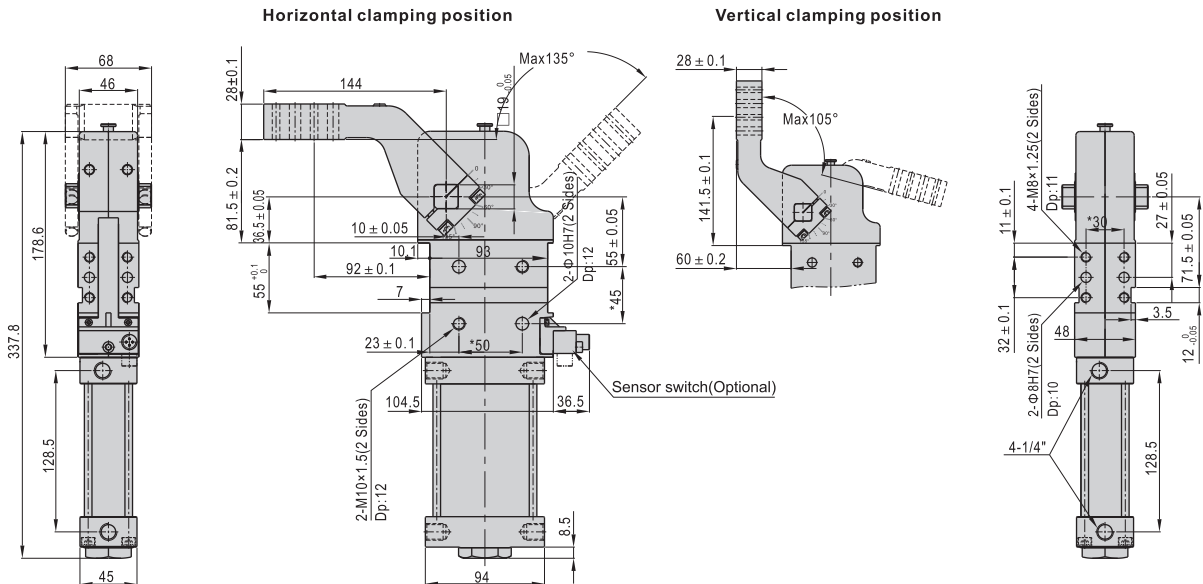

With * dimension: pin hole position tolerance: ± 0.02 . Thread hole position tolerance: ± 0.1 .

Power clamp cylinder - WGK SERIES

WGK Series

Dimensions

WGK63AM1(2)

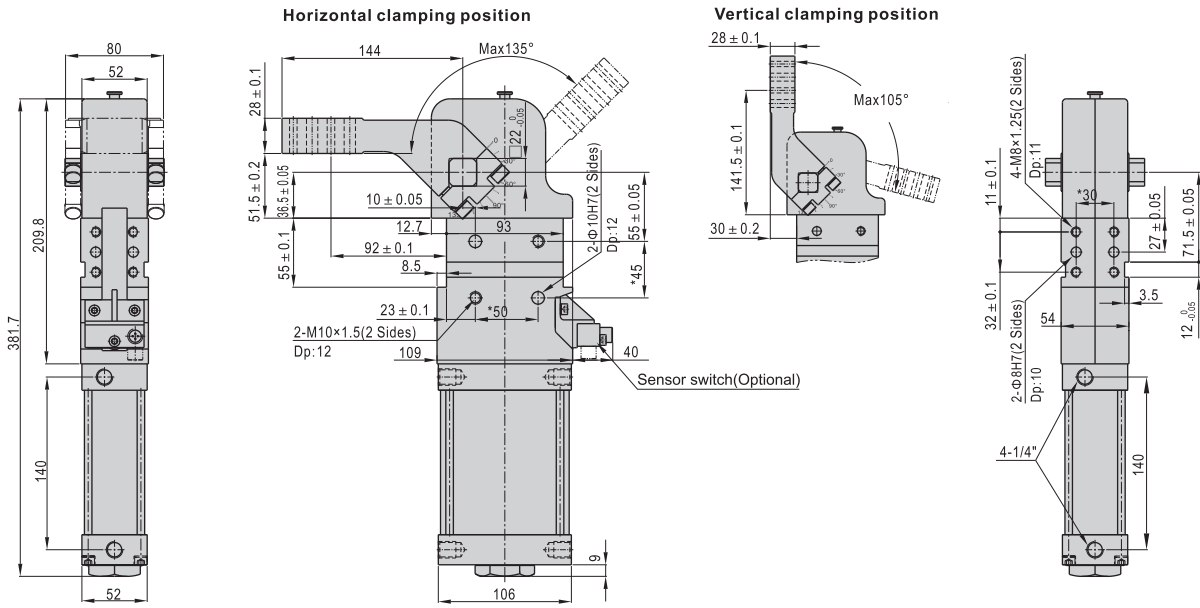

With * dimension: pin hole position tolerance: ± 0.02 . Thread hole position tolerance: ± 0.1 .

WGK63AM3(4)

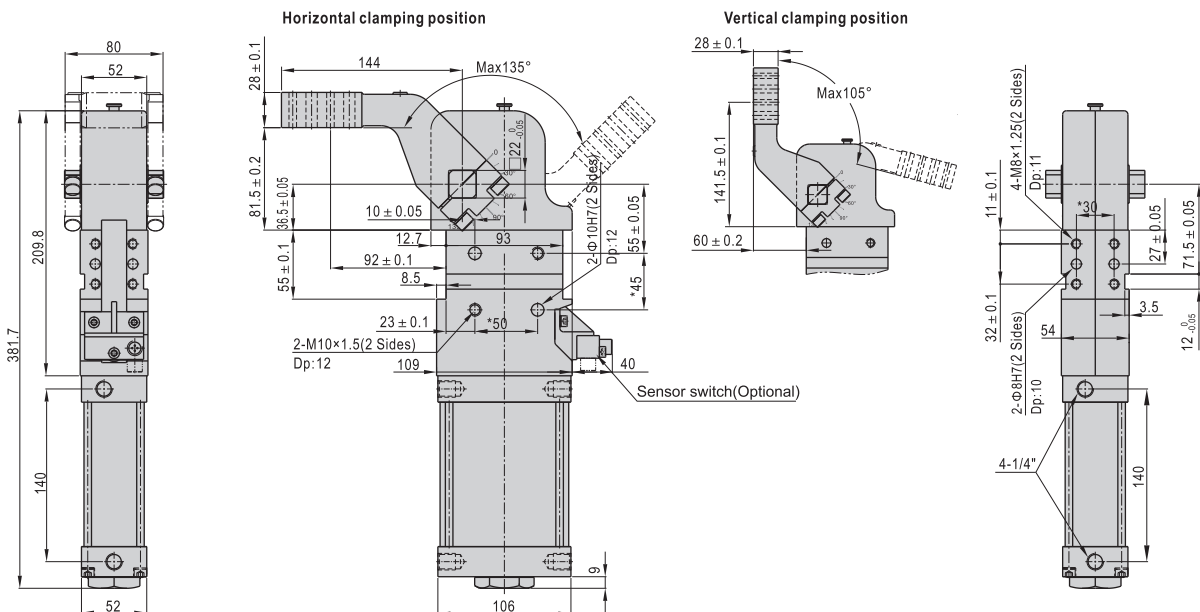

With * dimension: pin hole position tolerance: ± 0.02 . Thread hole position tolerance: ± 0.1 .

Power clamp cylinder - WGK SERIES

WGK Series- Air Inductive approaching sensor type



Model	WGK40□KA	WGK50□KA	WGK63□KA
Output torque (0.5 MPa)	120N.m	160N.m	380N.m
Acting Type	Double acting		
Fluid	Air (to be filtered by 40 μm filter element)		
Operating pressure	0.3~ 0.8 MPa (43 ~ 116 psi)		
Proof pressure	1.2 MPa (175 psi)		
Temperature	-10 ~ 60 °C		
Opening angle	15° /30° /45° /60° /75° /90° /105° /120° /135°		
Min. opening and closure time	1 second clamping, 1 second opening		
Position sensing	Air Inductive approaching sensor		
Cushion type	Air buffer		
Weight (135°) ①	2.2 kg	4.0 kg	5.5 kg
Port size ②	1/8"	1/4 "	

① This weight includes 15 mm offset clamping arm;
 ② PT thread , G thread and NPT thread are available.

Compendium of WGK (Air Inductive approaching sensor type) Series

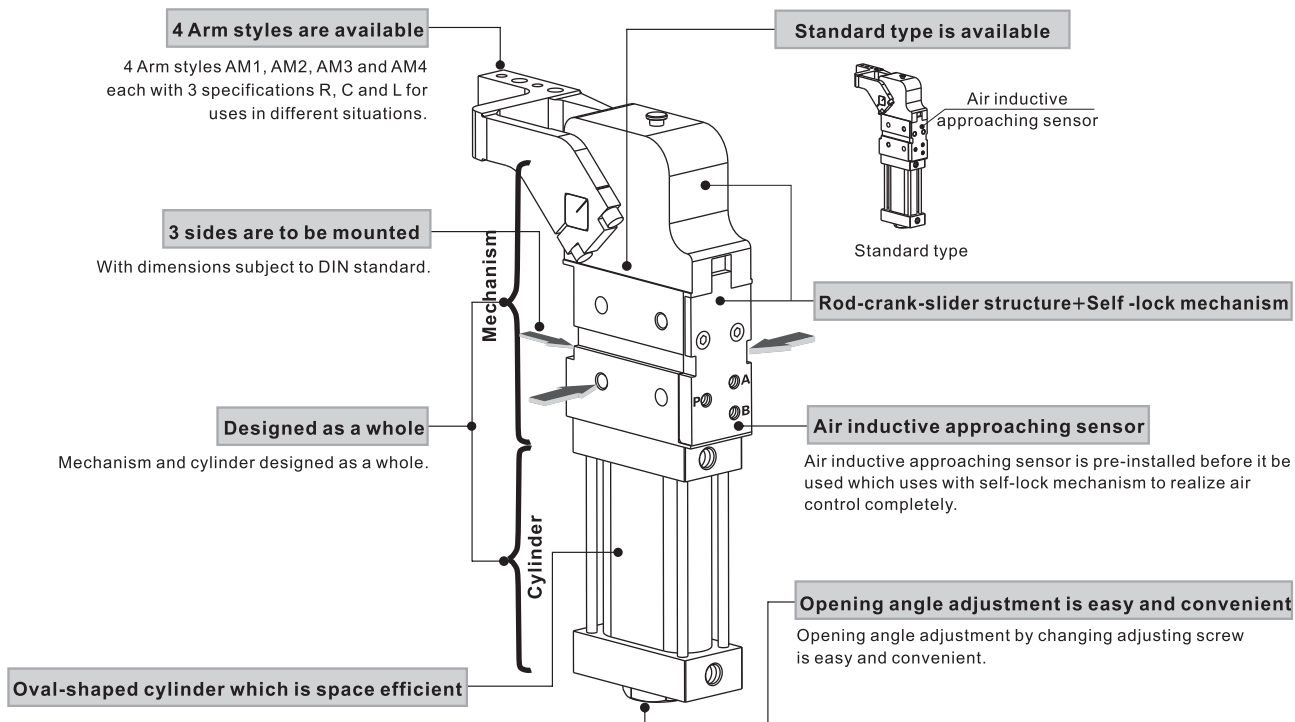

Installation and application

1. Can be mounted from three sides.
2. Air inductive approaching sensor is obturated completely which avoid dust and splashed welding slag breaking cylinders.
3. Adapt to air control loop's equipment. Main signal export to self-lock mechanism to check clamp or unclamp's position by air pressure signal.
4. Please connect air inductive approaching sensor's ports by the below sketch map.

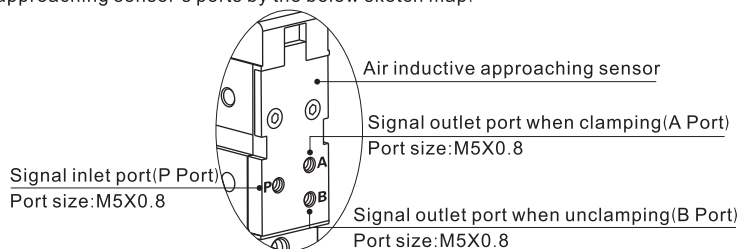

Power clamp cylinder - WGK SERIES

WGK Series- Clamp arm and Adjusting screw



WGK Series- Clamp arm and Adjusting screw

Accessories/Cylinder type		WGK40	WGK50	WGK63	WGK80	
Adjusting screw	F-WGK□□ X15LM	F-WGK□□ X30LM	●	●	●	●
	F-WGK□□ X45LM	F-WGK□□ X60LM	●	●	●	●
	F-WGK□□ X75LM	F-WGK□□ X90LM	●	●	●	●
	F-WGK□□ X105LM	F-WGK□□ X120LM	●	●	●	●
	F-WGK□□ X135LM		●	●	●	●
Clamp arm	F-WGK□□ AM1R	F-WGK□□ AM3R	●	●	●	●
	F-WGK□□ AM1C	F-WGK□□ AM3C	●	●	●	●
	F-WGK□□ AM1L	F-WGK□□ AM3L	●	●	●	●
	F-WGK□□ AM2R	F-WGK□□ AM4R		●	●	●
	F-WGK□□ AM2C	F-WGK□□ AM4C		●	●	●
	F-WGK□□ AM2L	F-WGK□□ AM4L		●	●	●

Adjusting screw ordering code

F - WGK 63 X 135 LM



① ② ③ ④ ⑤

① Accessory code	② Cylinder type	③ Bore size	④ Adjusting angle	⑤ Adjusting screw code
	WGK: Power clamp cylinder (Double acting)	40: Φ 40mm 50: Φ 50mm 63: Φ 64mm 80: Φ 80mm	15: 15° 30: 30° 45: 45° 60: 60° 75: 75° 90: 90° 105: 105° 120: 120° 135: 135°	LM: Adjusting screw

Clamp arm ordering code

F - WGK 63 AM1C

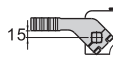
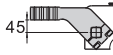
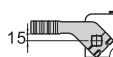
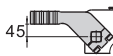
① ② ③ ④

① Accessory code	② Cylinder type	③ Bore size	④ Clamping arm
	WGK: Power clamp cylinder (Double acting)	40: Φ 40mm	Blank: No clamping arm
			AM1: Offset 15mm 
			AM3: Offset 45mm 
		50: Φ 50mm 63: Φ 64mm 80: Φ 80mm	Blank: No clamping arm
			AM1: Offset 15mm 
			AM3: Offset 45mm 
			AM2: Offset 15mm 
			AM4: Offset 45mm 

Power clamp cylinder - WGK SERIES

WGK Series- Clamp arm and Adjusting screw

Dimensions of clamp arm

F-WGK40AM1 □

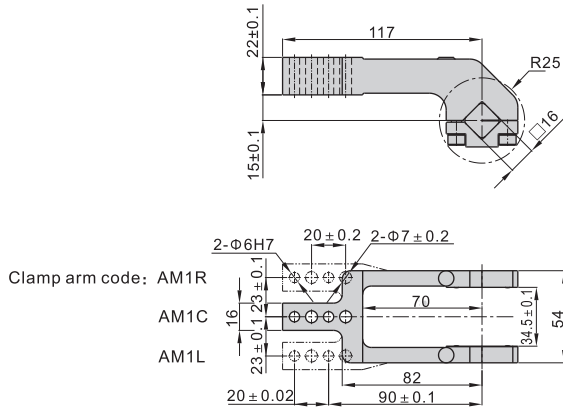

F-WGK40AM3 □

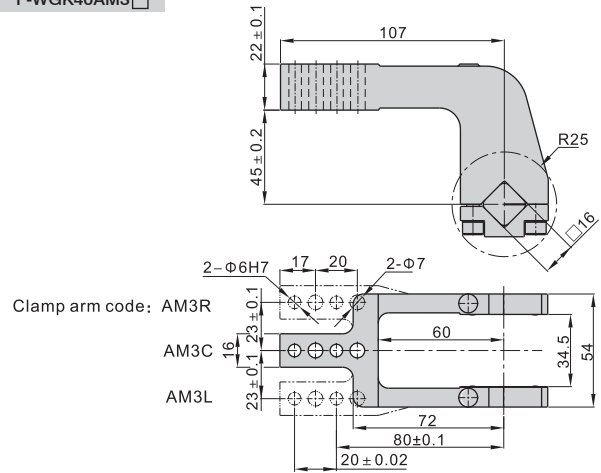

F-WGK50AM1 □

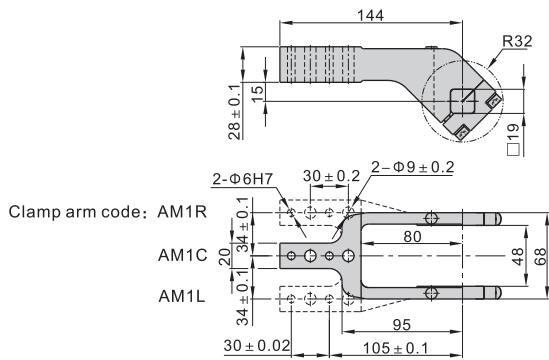

F-WGK50AM2 □

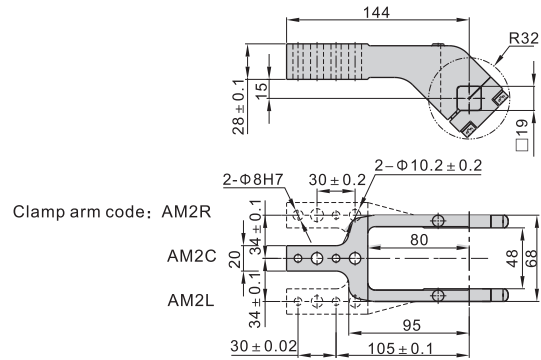

F-WGK50AM3 □

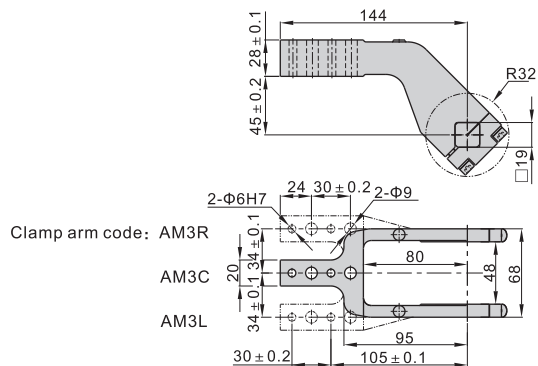

F-WGK50AM4 □

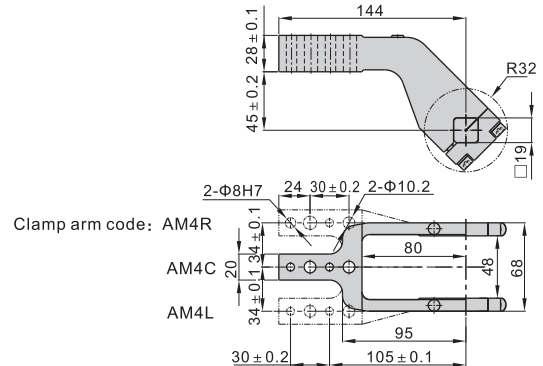

Power clamp cylinder - WGK SERIES

WGK Series - Sensor switch



Specification

Operating range	2mm
Voltage range	10~30V DC
Output type	N.O., PNP, NPN
Rated DC	150mA(max)
Switch frequency	30Hz
Shell material	PBT
Switch status indication	Clamping: Red Opening: Yellow
Voltage indication	Green

Ordering code

DS1 KP 63

① ② ③

① Model	② Output type	③ Bore size
DS1: Sensor switch	KP: PNP KN: NPN	63(Bore size: 40、50、63) 80(Bore size: 80)

Hookup

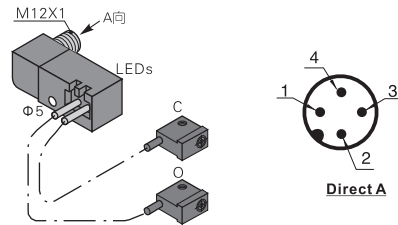
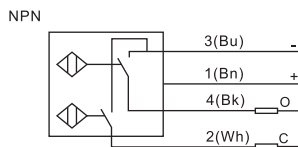
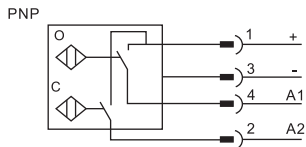

Installation and application of sensor switch

1. Sensor switch is well assembled before leaving factory which is free of adjusting. If you need to change terminals' wiring direction, change new sensor or rearrange angle, please do as follows:

1.1) Steps of changing terminals' wiring direction:

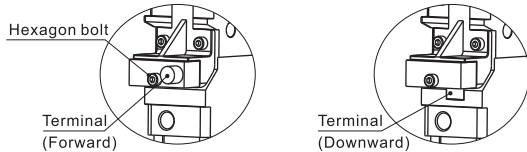

(See figure above.) Unscrew the hexagon bolt→dismount sensor's Terminal→change terminals' wiring direction as you need→remounting→screw up the hexagon bolt.

1.2) Steps of change new sensor switch:

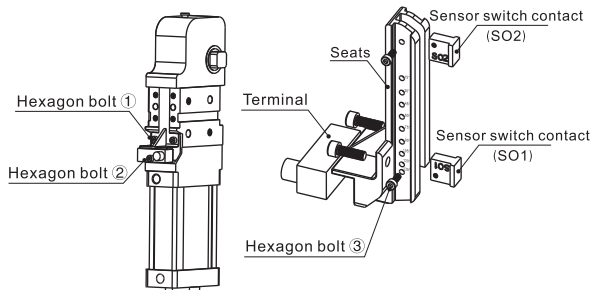

(See figure above.) unscrew two hexagon bolts ①→dismount sensor seats as a whole→unscrew two hexagon bolts ③→dismount two sensor switch contacts(SO1/SO2)→unscrew hexagon bolt ②→remove the sensor switch→choose new sensor switch→replace new sensor switch contact and screw up hexagon bolt ②→replace new wiring box and screw up hexagon bolt ①→finished.

Recommended lock torque of hexagon bolt is listed in the following table:

Bore size	Recommended lock torque of hexagon bolt ①		Recommended lock torque of hexagon bolt ②		Recommended lock torque of hexagon bolt ③	
	Hexagon bolt type	Lock torque(N.m)	Hexagon bolt type	Lock torque(N.m)	Hexagon bolt type	Lock torque(N.m)
40、50	M3×0.5	1.2~1.5	M5×0.8	4.0~5.0	M3×0.5	1.2~1.5
63、80	M5×0.8	4.0~5.0				

1.3) Steps of readjusting angle. For more details, see latter contents.

1.4) Sensor switch's connection:

Sensor switch's connection need to use relevant male connector, which have separate male connector, and with wire male connector to be choosed. The ordering code as below:

Name: On end cable(3 meters length)	Name: L shape cable(3 meters length)	Name: On end connector(rotundity)	Name: L shape connector (rotundity)
Ordering code: X-F-PPVCS	Ordering code: X-F-PPVCL	Ordering code: X-F-PPVCV	Ordering code: X-F-PPVCH

Power clamp cylinder - WGK SERIES

WGK Series - Sensor switch

Installation and application

1. Mount the cylinder at desired place with bolts and locating pin after choosing a mounting surface. Connect the cylinder and control valve with joint and rubber hose. To adjust the opening and closure speed, our pneumatic power welding clamp is equipped with return stroke air buffering. Buffering cannot function well if the clamping arm is over-weighted so that clamping arm weight must be within the allowable limit;
2. Using clamping arm beyond the listed in this catalog is forbidden.
3. Workpiece mounting method:

3.1) When only clamping torque is used for clamping:

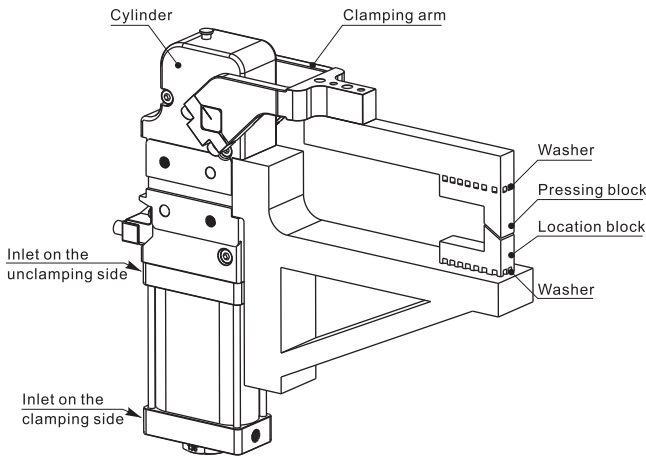

Please follow the steps to mount the workpiece onto the clamping arm:

- A) Clamping the arm:** supply compressed air through the inlet on the clamping side to keep the arm and pressing block at the closure position simultaneously. Make sure the arm is locked up.
- B) Adjusting the clamping gap:** adjust the spacer under the mentioned state to make the pressing block in line with the workpiece's thickness. (At this moment no clamping torque is produced theoretically.)
- C) Applying clamping torque:** Insert the spacer furthermore under the mentioned state until the gap is smaller than the workpiece's thickness and desired clamping torque is produced. (Make sure the mechanism passes the dead position to produce self-locking i.e. the retaining pin is pushed out.)

3.2) When hard braking is used for clamping:

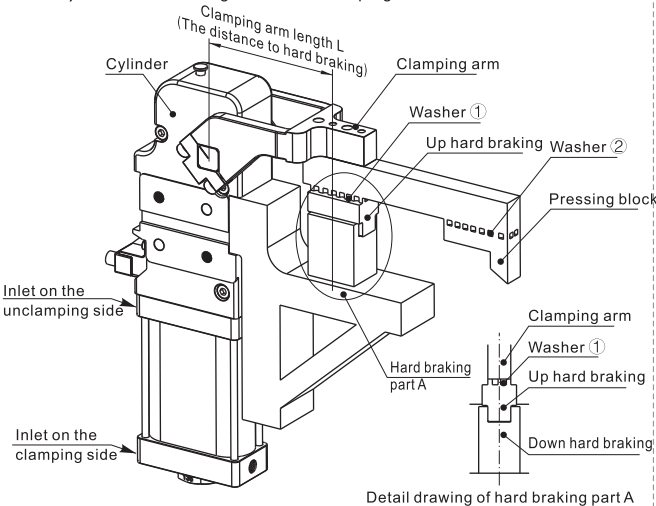

Detail drawing of hard braking part A

Please follow the steps to mount the workpiece onto the clamping arm:

- A) clamping the arm:** supply compressed air through the inlet on the closure side to keep the arm and the braking block at the clamping position simultaneously. Make sure the arm is locked up;

B) Adjusting the clamping gap: Adjust washer ① under the mentioned state until the gap between the upside braking block and downside one. (At this moment no clamping torque is produced theoretically.)

C) Applying clamping torque: insert the washer ① furthermore under the mentioned state to produce desired clamping torque. (Make sure the mechanism passes the dead position to produce self-locking i.e. the retaining pin is pushed out.)

D) Adjust washer ② under the state mentioned in C to make the pressing block in contact with the workpiece.

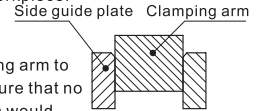

3.3) When side guide plate is mounted:

Side guide plate is mounted on the clamping arm to prevent transverse movement and make sure that no transverse load is applied and that the arm would not be stuck.

4. Angle adjusting method:

Standard adjusting angle range of the pneumatic clamp is 15°~135°.

Opening angle can be changed via changing cylinder's stroke distance or the sensor's position;

4.1) Step 1 of adjusting angle--change of sensor's position:

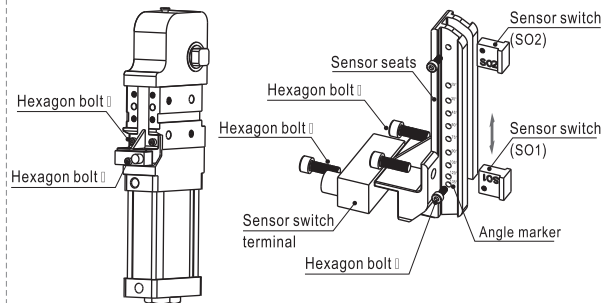

A) Unscrew hexagon bolt ① with inner hexagon wrench to take out the sensor seats;

B) Unscrew hexagon bolt ③ with inner hexagon wrench to take out sensor SO1 and align it to your desired angle indication position and re-screw up hexagon bolt ③. (Note: when mounting sensor SO1, the number "SO1" should point downward except 15°.)

C) After the sensor's position is adjusted, replace the sensor seats by screwing up hexagon bolt ① with inner hexagon wrench (lock-up torque by related contents).

Note: 1) sensor SO2 controls the cylinder's end stroke position and its mounting position is well set when leaving factory and is not changeable.

2) the sensor wiring box is provided with two outgoing orientations: forward and downward. Unscrew hexagon bolt ② and then you can change the wiring box orientation. After that, screw up hexagon bolt ②.

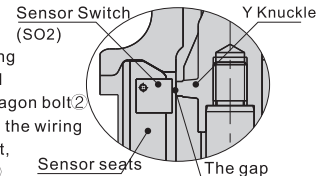

3) When remounting the sensor fix to its original position, the gap between the sensor and Y-knuckle should be less than 1.5mm. Otherwise, the sensor may not function well.

4.2) Step 2 of adjusting angle--change of the cylinder's stroke distance:

The relation between the opening angle of clamping arm and cylinder's stroke distance is listed as follows:

Opening angle /Type	WGK40	WGK50	WGK63	WGK80
15°	20.2	21.6	23.1	36.1
30°	28.1	30.2	33.4	50.5
45°	34.8	37.5	41.6	62.7
60°	41.4	44.6	49.7	74.5
75°	48.0	51.8	57.5	86.3
90°	54.8	59.2	65.7	98.1
105°	61.5	66.4	73.8	109.6
120°	67.4	72.7	81.0	119.5
135°	71.6	77.3	86.2	126.4

Power clamp cylinder - WGK SERIES

WGK Series - Sensor switch

During actual operation, the cylinder's stroke can be changed by changing the adjusting screw at the bottom to control the clamping arm's opening angle. Detailed description is

as follows:

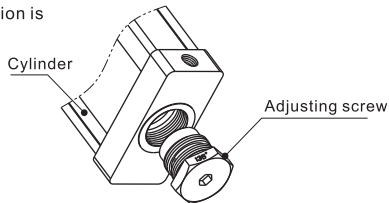

- A) Unscrew original adjusting screw with inner hexagon wrench
- B) Choose suitable adjusting screw according to actual need (the bottom is marked with corresponding opening angle).
- C) Screw up new adjusting screw into the cylinder's end cap.

5. Mounting clamping arm:

The clamping arm is already mounted when leaving factory which can be remounted by yourself horizontally or vertically according to your actual need.

5.1) Mounting clamping arm horizontally:

Unscrew 4 hexagon bolts on both sides of the clamping arm to remove V-shaped block and then the clamping arm for substituting your desired one.

When mounting, please note the direction of the indicating line on the pivot.

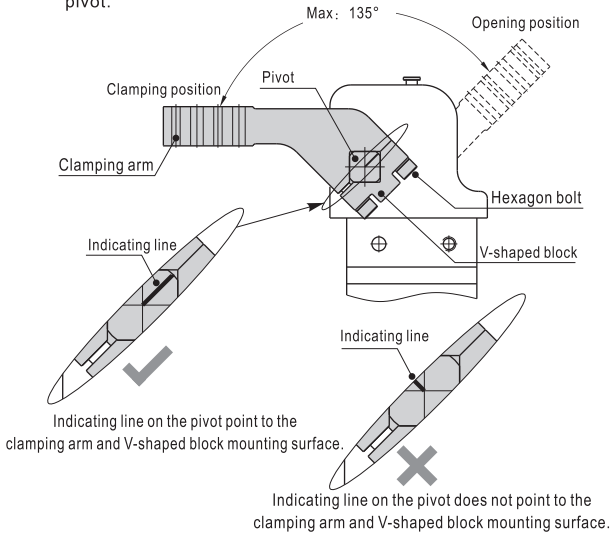

5.2) Mounting clamping arm vertically:

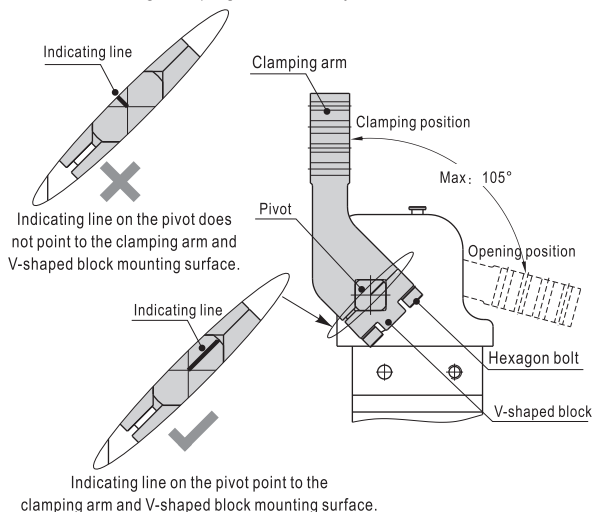

5.3) V-shaped block mounting:

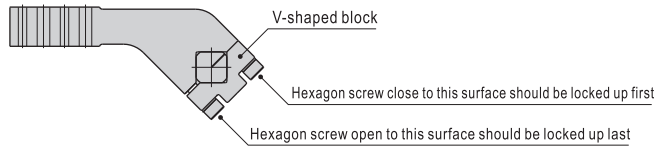

5.4) Holding torque of clamping arm (recommended):

When holding clamping arm, please choose recommended value in the following list:

Bore size	Bolt type	Holding torque (N.m)
40	M6 × 1.0	13.8
50	M6 × 1.0	13.8
63	M8 × 1.25	33.0
80	M10 × 1.5	66.0

6. Self-lock function:

At the end of stroke, the crank-slider mechanism passes the dead point and gets self-locked up. The retaining pin gets pushed up at this moment. Even when compressed air is off, the cylinder can remain at closure state for safety. To open self-locking of the crank-slider mechanism, push down the retaining pin when compressed air is off.

Warning:

Pushing down the retaining pin may cause clamping arm to spring off at closure state.

So when using the pin, please get yourself away from the clamping arm's operation range.

