

## WWLS SERIES CARTRIDGE SHUTTLE VALVES

### WWLS- 02 Series

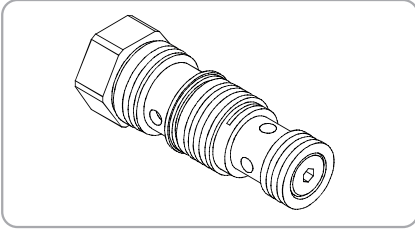

Shuttle Valves, cartridge-style hydraulic check valve, for use in blocking circuits where a priority of flow / direction is given to a higher pressure circuit over a lower one.

#### Performance

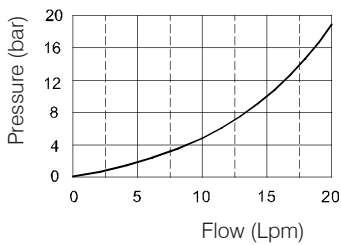

#### Specifications

Model Number	Max. Pressure (bar)	Flow (lpm)	Weight (Kg)
WWLS-02	350 (5076 psi)	10(2.64 gpm)	0.14 (0.31 lbs)
Fluid Type		ISO VG 32, 46, 68	
Viscosity cSt		10~400 (59~1854 SSU)	
Operating Temperature		-15~70 (-5~158°F)	
Contamination Level		ISO4406.21/19/16 NAS1638,10	

#### How To Order

1	2
<b>WWLS</b>	<b>02</b>

**1 Valve Series**  
WWLS=Cartridge Shuttle Valves

**2 Subplate Mounting Size**  
02 :T-11A Cavity :CST-11A

#### Control Port (S)

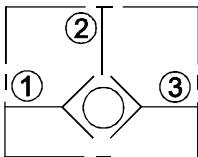

#### Dimensions

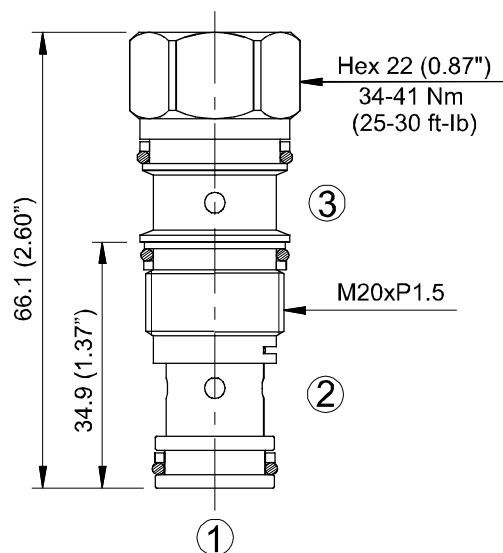

**WWLS SERIES CARTRIDGE SHUTTLE VALVES**

**WWLS- 04 Series**

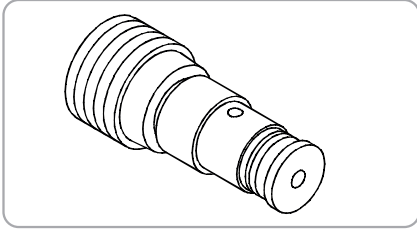

Shuttle Valves, cartridge-style hydraulic check valve, for use in blocking circuits where a priority of flow / direction is given to a higher pressure circuit over a lower one.

**Performance**

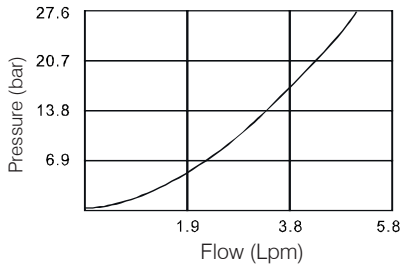

**Specifications**

Model Number	Max. Pressure (bar)	Flow (lpm)	Weight (Kg)
WWLS-04	350 (5076 psi)	6(1.59 gpm)	0.01(0.02 lbs)
Fluid Type		ISO VG 32, 46, 68	
Viscosity cSt		10~400 (59~1854 SSU)	
Operating Temperature		-15~70 (-5~158°F)	
Contamination Level		ISO4406.21/19/16 NAS1638,10	

**How To Order**

1
2  
**WWLS 04**

- 1 Valve Series**  
WWLS=Cartridge Shuttle Valves
- 2 Subplate Mounting Size**  
Size : 04 Cavity CS04-B3

**Control Port (S)**

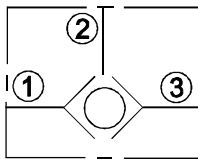

**Dimensions**

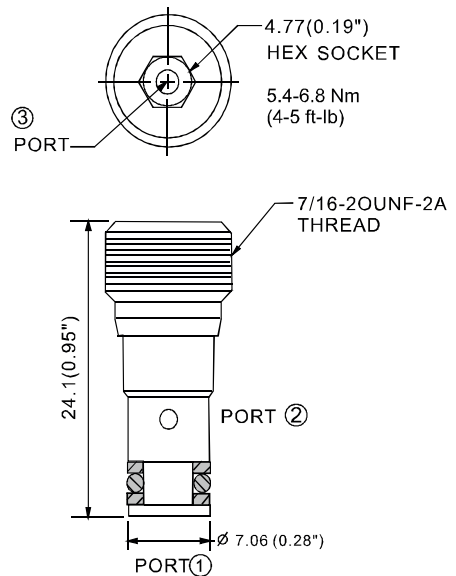

**WWLS SERIES CARTRIDGE SHUTTLE VALVES**

**WWLS- 08 Series**

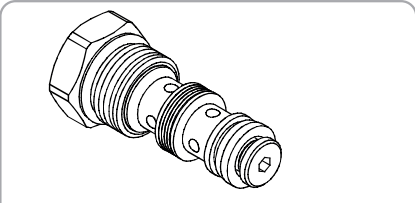

**Performance**

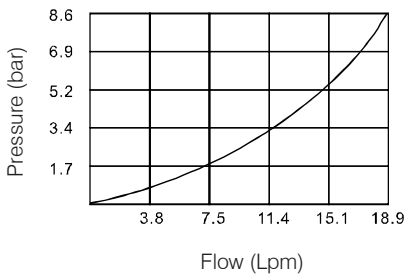

**Specifications**

Model Number	Max. Pressure (bar)	Flow (lpm)	Weight (Kg)
WWLS-08	350 (5076 psi)	19(5.02 gpm)	0.07 (0.15 lbs)
Fluid Type		ISO VG 32, 46, 68	
Viscosity cSt		10~400 (59~1854 SSU)	
Operating Temperature		-15~70 (-5~158°F)	
Contamination Level		ISO4406.21/19/16 NAS1638,10	

**How To Order**

<b>1</b>	<b>2</b>
<b>WWLS</b>	<b>08</b>

- 1 Valve Series**  
WWLS=Cartridge Shuttle Valves
- 2 Porting**  
Size :08 Cavity CS08-3N

**Control Port (S)**

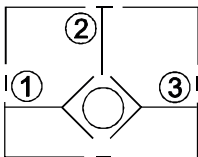

**Dimensions**

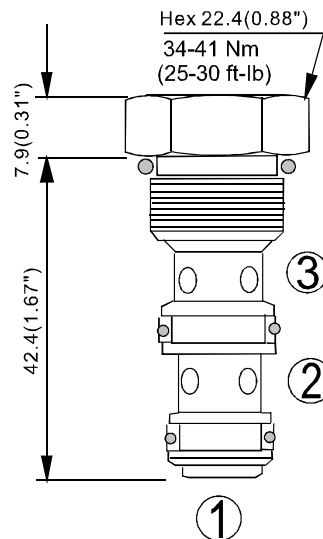

**WWLS SERIES CARTRIDGE SHUTTLE VALVES**

**WWLS- 10 Series**

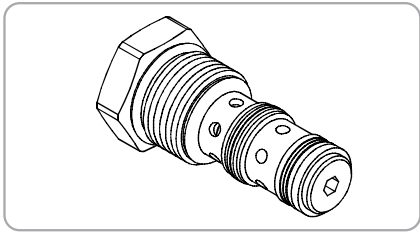

Shuttle Valves, cartridge-style hydraulic check valve, for use in blocking circuits where a priority of flow / direction is given to a higher pressure circuit over a lower one.

**Performance**

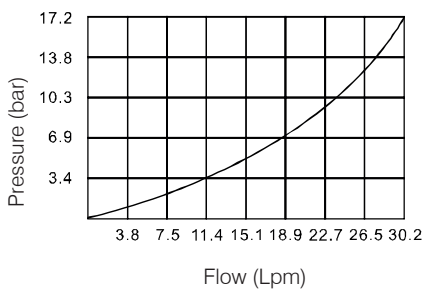

**Specifications**

Model Number	Max. Pressure (bar)	Pilot Ratio	Adjustment Pressure	Max. Flow (lpm)	Weight (Kg)
WWLS-10	350 (5076 psi)	1.5:1/3:1/4.5:1/10:1	★~350	480(105.50 gpm)	1.6 (3.53 lbs)
Fluid Type			ISO VG 32, 46, 68		
Viscosity cSt			10~400 (59~1854 SSU)		
Operating Temperature			-15~70 (-5~158°F)		
Contamination Level			ISO4406.21/19/16 NAS1638,10		

**How To Order**

<b>1</b>	<b>2</b>
<b>WWLS</b>	<b>10</b>

- 1 Valve Series**  
WWLS=Cartridge Shuttle Valves
  
- 2 Subplate Mounting Size**  
Size :10 Cavity CS10-3N

**Control Port (S)**

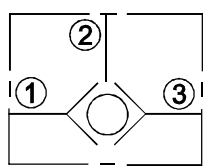

**Dimensions**

